

NERC

NORTH AMERICAN ELECTRIC
RELIABILITY CORPORATION

PRC-019-2 Technical Reference Document

September 2021

RELIABILITY | RESILIENCE | SECURITY



**3353 Peachtree Road NE
Suite 600, North Tower
Atlanta, GA 30326
404-446-2560 | www.nerc.com**

Table of Contents

Preface	iv
Overview.....	v
Purpose	v
Scope	v
Chapter 1: Engineering Background.....	1
Traditional Synchronous Generation Capability Curve	1
Control Systems	1
Field Winding Overexcitation	2
Stator Over Flux (Overexcitation).....	2
Field Winding Underexcitation (limiter etc.).....	2
Loss of Field Protection Schemes	3
Protection Coordination Philosophy	4
Inverter Based Resource Generating Facility.....	4
Synchronous Condensers	6
Blackstart Generators	6
Steady-State Stability Limit (SSSL)	6
Equipment or Protection System Changes.....	7
Chapter 2: Coordination Validation	8
Chapter 3: Example Calculations.....	9
Synchronous Generation Example	9
Manual Steady State Stability Limit (SSSL):	11
Generator Capability Curve	15
Generator Over Flux Capability Curve:.....	16
Generator Step-Up (GSU) Transformer Over Flux Capability Curve:.....	17
Unit Auxiliary Transformer (UAT) Over Flux Capability Curve:.....	17
Generator Field Winding Overexcitation Capability Curve:.....	18
Excitation System Underexcitation Limiter (UEL).....	18
Excitation System Field Winding Overexcitation Limiter (OEL).....	19
Excitation System Field Winding Overexcitation Protection (OEP).....	19
Excitation System Stator Volts per Hertz Limiter	21
V/Hz Overexcitation Protection Scheme:	21
Field Winding Overcurrent (50/51) Overload Protection Scheme	23
Generator Loss of Field (40) Protection Scheme	24

Table of Contents

Synchronous Condenser Example35

 Manual Steady State Stability Limit (SSSL):37

 Generator Capability Curve37

 Condenser Over Flux Capability Curve38

 Generator Step-Up (GSU) Transformer Over Flux Capability Curve38

 Unit Auxiliary Transformer (UAT) Over Flux Capability Curve39

 Condenser Field Winding Overexcitation Capability Curve39

 Excitation System Underexcitation Limiter (UEL)40

 Excitation System Field Winding Overexcitation Limiter (OEL)40

 Excitation System Field Winding Overexcitation Protection (OEP)41

 Excitation System Stator Volts per Hertz Limiter42

 V/Hz Overexcitation Protection Scheme43

 Field Winding Overcurrent (50/51) Overload Protection Scheme44

 Condenser Loss of Field (40) Protection Scheme45

Dispersed Power Producing Resources Example52

 Dispersed Power Producing Resource Data55

 IBR Voltage Analysis56

 Bus Continuous Voltage Capability56

 Short Time Overvoltage Capability57

 POI Voltage Limits57

 Feeder Undervoltage (27) Protection Settings58

 Collector Bus Overvoltage (59) Protection Settings58

 POI Undervoltage (27) Protection Settings59

 POI Overvoltage (59) Protection Settings59

Chapter 4: References64

Appendix A: Contributors65

Preface

Electricity is a key component of the fabric of modern society and the Electric Reliability Organization (ERO) Enterprise serves to strengthen that fabric. The vision for the ERO Enterprise, which is comprised of the North American Electric Reliability Corporation (NERC) and the six Regional Entities (REs), is a highly reliable and secure North American bulk power system (BPS). Our mission is to assure the effective and efficient reduction of risks to the reliability and security of the grid.

Reliability | Resilience | Security
Because nearly 400 million citizens in North America are counting on us

The North American BPS is made up of six RE boundaries as shown in the map and corresponding table below. The multicolored area denotes overlap as some load-serving entities participate in one RE while associated Transmission Owners (TOs)/Operators (TOPs) participate in another.

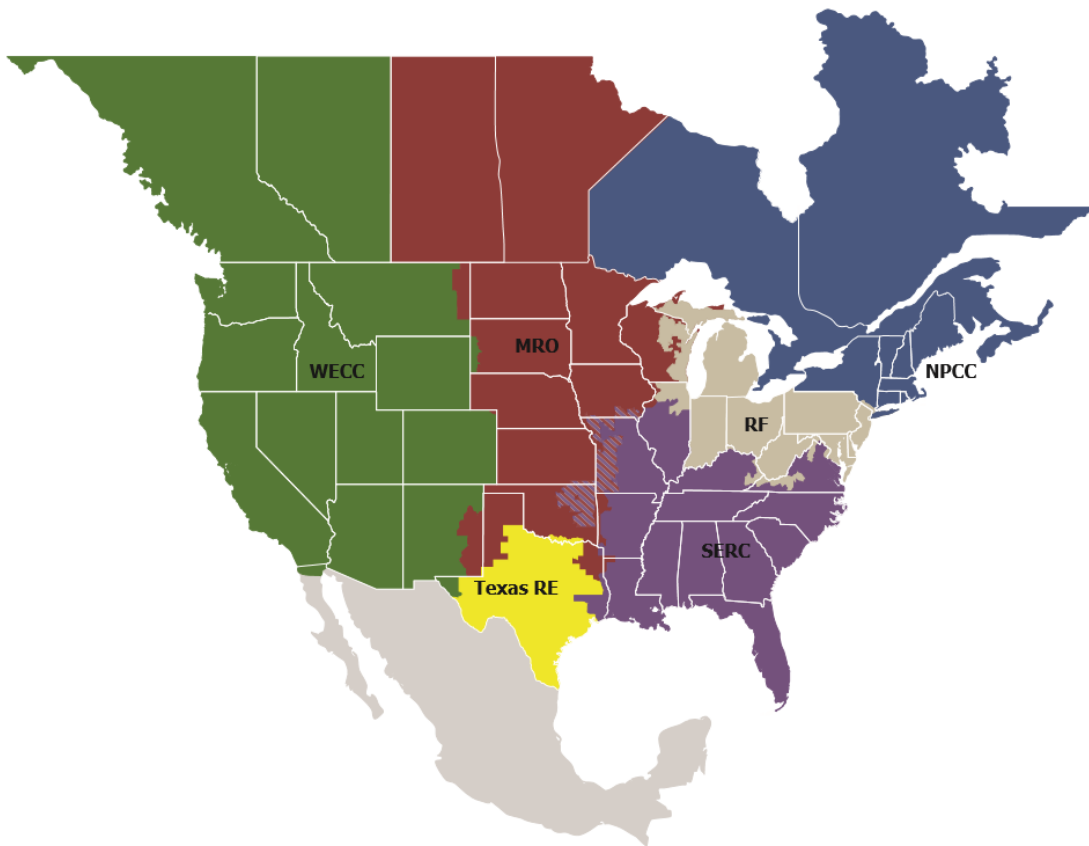

MRO	Midwest Reliability Organization
NPCC	Northeast Power Coordinating Council
RF	ReliabilityFirst
SERC	SERC Reliability Corporation
Texas RE	Texas Reliability Entity
WECC	WECC

Overview

Purpose

This document provides technical guidance related to NERC Standard PRC-019-2. Included is engineering background to help entities understand the coordination of control systems, protective functions, and equipment capabilities. It is also intended to establish reasonable assumptions that may be used in the calculations to meet the intent of this standard. Example calculations utilizing these engineering concepts are included to demonstrate compliance. These examples DO NOT represent the only method for showing compliance. They are simply an example of the engineering principles and philosophies an entity may consider for compliance with the standard.

This document identifies the different variables and system conditions associated with generation control and protection coordination. Generation resources have inherent differences that can be analyzed through the methodologies outlined in this document. The diversity of the systems throughout the industry may require analysis from a different vantage point.

Scope

This document can serve as technical reference for Generator Owners (GO) and Transmission Owners (TO) who are seeking to demonstrate compliance with PRC-019-2 Requirements R1 and R2. The standard requirements are copied below, for the reader's convenience.

- R1.** At a maximum of every five calendar years, each Generator Owner and Transmission Owner with applicable Facilities shall coordinate the voltage regulating system controls, (including in-service¹ limiters and protection functions) with the applicable equipment capabilities and settings of the applicable Protection System devices and functions.
 - 1.1.** Assuming the normal automatic voltage regulator control loop and steady-state system operating conditions, verify the following coordination items for each applicable Facility:
 - 1.1.1.** The in-service limiters are set to operate before the Protection System of the applicable Facility in order to avoid disconnecting the generator unnecessarily.
 - 1.1.2.** The applicable in-service Protection System devices are set to operate to isolate or de-energize equipment in order to limit the extent of damage when operating conditions exceed equipment capabilities or stability limits.
- R2.** Within 90 calendar days following the identification or implementation of systems, equipment or setting changes that will affect the coordination described in Requirement R1, each Generator Owner and Transmission Owner with applicable Facilities shall perform the coordination as described in Requirement R1. These possible systems, equipment or settings changes include, but are not limited to the following:
 - Voltage regulating settings or equipment changes;
 - Protection System settings or component changes;
 - Generating or synchronous condenser equipment capability changes; or
 - Generator or synchronous condenser step-up transformer changes.

This document provides examples showing coordination of voltage control systems, Protection Systems and equipment capabilities for the following types of resources:

- Traditional Synchronous Generation

- Type 1 & Type 2 Wind Turbine
- Inverter Based Resources:
 - Type 3 Doubly Fed Induction Generator (DFIG) or Doubly Fed Asynchronous Generator (DFAG) Wind Turbine
 - Type 4 Full Conversion Wind Turbine
 - Photovoltaic (Solar) System
 - Battery Energy Storage Systems (BESS)

Chapter 1: Engineering Background

This section provides in-depth discussion of protection systems and generator performance that are under the purview of PRC-019 standard. Key concepts and reasonable assumptions will be presented to establish a baseline level of knowledge for coordination. It also explains the theory behind various protection systems, control systems, and different types of generation resources. It is critical that an entity understand these concepts for protection and control system coordination.

Traditional Synchronous Generation Capability Curve

The capability curve characteristic for a synchronous generator is typically plotted on a 1.0 per unit terminal voltage basis. This standard does not specify a per unit voltage for evaluation of generator capability curves (GCC). Per IEEE C37.102, a capability curve based on 0.95 per unit voltage may be used for coordination since it is the minimum voltage the GCC is valid for. This voltage condition will provide a conservative scenario for coordination with the loss-of-field curve characteristic.

The GCC is developed from three distinct limitations of the machine: the rotor winding limit, the stator winding limit, and the stator end-iron limit. The rotor winding limit (RWL) defines the internal field current capability and is governed by the following equations:

$$\text{center}_{RWL} = -\left(\frac{V_{gen}^2}{X_{d-G}}\right)$$
$$\text{radius}_{RWL} = V_{gen} \times \left(\frac{E_G}{X_{d-G}}\right)$$

The stator winding limit (SWL) defines the current capability of the stator winding and is governed by the following equations:

$$\text{center}_{SWL} = 0$$

$$\text{radius}_{SWL} = MVV_{gen}$$

The stator end-iron limitation (SEIL) defines the magnitude of VARs the generator is capable of absorbing from the system. This limitation is highly dependent on the thermal capability of the stator end-core. Thus, this capability is typically defined by the OEM.

Control Systems

Excitation Systems that employ protection functions (i.e. V/Hz tripping, etc.) may be evaluated for coordination like protection systems. The excitation control system and relays associated with a generating unit tend to receive their reference voltage and currents from the same source, the terminals of a generator. These systems typically react in the same manner during abnormal system or generator conditions that may damage the unit. Generator control systems with protection functions programmed to trip using operating quantities aligned with PRC-019, should be evaluated for coordination just like Protection Systems. These functions typically react to abnormal system or generator conditions to prevent a generator from exceeding its limitation. Thus, these systems can adhere to the requirements outlined in the standard for protection functions. An entity may disable protection functions within a control system and only enable them within a relay to simplify coordination. They may provide documentation of control system programming as evidence that the functions are disabled.

Field Winding Overexcitation

Overexcitation occurs when the excitation system applies an excess amount of dc current to the field winding. The field winding has a thermal limit that is typically defined by an inverse-time curve characteristic. During an overexcitation condition, primary protection is provided through control functions (e.g. limiters), within the excitation system, to prevent encroaching on this thermal capability. Protection functions act as a backup protection system, if the control functions fail, to prevent the field winding from exceeding the thermal capability.

Per IEEE Std 421.5, there are several OEL types “but all operate through the same sequence of events: Detect the overexcitation condition, allow it to persist for a defined time-overload period, and then reduce the excitation to a safe level.” The limiter may use field current, field voltage, exciter field current, or exciter field voltage as an operating quantity. This control function may operate based on an instantaneous or an inverse-time curve characteristic.

Overexcitation protection may be provided through a protection function in an excitation system and/or an external protection system (e.g. relay, etc.). These functions may use field current or field voltage as an operating quantity. Protective functions may operate based on an instantaneous or an inverse-time curve characteristic.

Stator Over Flux (Overexcitation)

The core flux of the stator winding is directly proportional to stator voltage and inversely proportional to the frequency/speed of the turbine. Overfluxing of the stator core may occur when an excitation system boosts the stator output voltage beyond the rated voltage or when the stator is at rated voltage with reduced turbine speed. These conditions can cause the stator flux to exceed the magnetic flux density capability of its core and saturate. This can lead to thermal damage due to flux spilling out and inducing eddy currents into components not designed to withstand these conditions. A V/Hz control function (e.g. limiter) provides primary protection to prevent the stator core from encroaching on its thermal capability. A protection function will provide backup protection in the event that the control function fails to prevent the stator core from encroaching upon its thermal capability.

There are different types of V/Hz limiters, but they all use the ratio of generator terminal voltage to generator frequency (rotor speed) as an operating quantity. This function operates similar to an OEL in that it will detect an excessive magnetic flux condition, allow it to persist for a defined time period, and then reduce the excitation current to bring the generator terminal voltage to an acceptable level (relative to the turbine frequency/speed). The limiter may use an instantaneous, definite-time, or inverse-time characteristic.

Protection for stator overflux may be provided via an excitation system protection function and/or an external protection system (e.g. relay, etc.). This function will typically use either volts per hertz or phase overvoltage as an operating quantity. The protective functions may utilize an instantaneous, definite-time, or inverse-time curve characteristic.

All equipment overexcitation (V/Hz) capabilities should be plotted on the same base voltage if coordination is verified on a single graph. It is recommended an entity use the generator voltage as the base for reference and transpose all other curves (GSU, UAT) to this base. The generator overexcitation capability is typically the most limiting curve and generator protection systems typically obtain their voltage input from the terminals of the generator. Hence, using the generator voltage as the base voltage will simplify the calculations. An entity may refer to IEEE C37.106: Guide for Abnormal Frequency Protection for Power Generating Plants for further information on stator overexcitation.

Field Winding Underexcitation (limiter etc.)

Underexcitation may occur when the field current is reduced too low or when the generator experiences a complete loss of field excitation. This condition may cause thermal damage to the generator and mechanical damage to the turbine. Excitation system control functions (e.g. Underexcitation Limiters) provide primary protection for an

underexcitation condition. If the control function fails to prevent further excitation reduction, then a protection function will act as a backup protection system to prevent generator damage.

An excitation system control function will attempt to stop further reduction of field excitation in response to an excessive underexcitation condition. Per IEEE Std 421.5, an underexcitation limiter (UEL) may use a combination of generator voltage and current or active and reactive power as an operating quantity.

The conversion of the operating characteristic from the R-X to the P-Q plane requires an entity to consider a voltage magnitude. The UEL may vary its characteristic in the P-Q plane through the use of a voltage magnitude V , V^2 , or not at all. If the UEL voltage dependency is V^2 then it will remain stationary in the R-X plane for coordination purposes with the loss of field (LOF) scheme. In this case, an entity may use 1.0 per unit to perform the conversion and verify coordination. If there is no voltage dependency or the voltage dependency is proportional to V , then an entity may use 0.95 per unit voltage to perform the conversion and verify coordination. The use of the lowest valid terminal voltage produces the closest boundary of the UEL, relative to the loss of field, in the R-X plane. If an entity does not know the voltage dependency of the UEL, using the lowest valid operating voltage, 0.95 per unit, is the most conservative approach for verifying coordination.

A loss of field scheme may provide protection for a complete loss of field excitation. This scheme may be located within the excitation system and/or an external protection system.

Loss of Field Protection Schemes

The negative offset Mho scheme (method #1¹) is the most commonly used scheme in the industry for detecting a loss of field condition. This scheme may appear to lack coordination with the stator core end iron limitation section of the GCC; however, during an actual loss of field condition the electrical parameters of a machine are drastically different than nominal conditions. When a synchronous machine loses the field excitation, the internal generator voltage (rotor voltage) will begin to decay; causing the generator to eventually lose synchronism and operate as an induction machine and absorb VARs from the system to re-excite the rotor. The machine will establish a new power equilibrium and operate asynchronously. The generator may produce less than 40% average real power while absorbing greater than 50% reactive power from the system for excitation. The apparent power plot will consist of a smaller real power output with a larger negative reactive power component. Thus, the area of coordination with the generator capability curve will be smaller compared to normal operating conditions.

A loss of field event can cause stator winding overloads, rotor damage, torque pulsations (due to loss of synchronization with the power system), and stator end-core damage. The reactive power transient, following a loss of field event, is highly dependent on the machine load levels prior to the contingency. This is because the slip between the generator and the system is directly correlated with initial generator loading; while the apparent impedance measured by the protection system is inversely correlated with slip. If heavily loaded (large magnitude of mechanical input power), the slip will be high, and the machine will absorb VARs in excess of the machine's nominal rating. This condition is categorized as a severe loss of field event and employing an instantaneous trip or minimal time delay is the industry standard. If a machine is producing a lower magnitude of real power (lightly loaded), a loss of field will result in a lower slip and cause the apparent impedance measured by the protection system to be larger. This scenario exposes this Mho element to stable power swings. Therefore, it is industry standard to use a time delay to avoid element misoperations while still providing adequate protection to the machine.

An entity may refer to IEEE C37.102: Guide for AC Generator Protection for further information on loss of field protection schemes.

¹ See IEEE Std C37.102 Guide for AC Generator Protection

Protection Coordination Philosophy

Coordination of protective relays is an art that varies between individual organizations based on their inherent philosophies. There is one faction that prefers their protective function lie just beyond, on the ragged edge, of equipment capability to allow the unit to operate up to its full potential. There is another faction that prefers their protective relays trip just before a machine reaches its capability. Both approaches are reasonable for meeting the requirements of PRC-019; as long as the protection scheme is within reasonable margin from the machine's capability (i.e. measurement errors, etc.) or follows protection philosophies based on objective reasoning (i.e. loss of field methodologies, etc.) from IEEE C37.102.

Inverter Based Resource Generating Facility

A typical Inverter Based Resource (IBR) Generating Facility generation plant consists of multiple Inverter Based Resources (IBR) branching off medium voltage (MV) feeders (e.g. 34.5kV). These resources are connected to MV collection feeders using step up transformers. Each IBR typically has local control with a control function that regulates the output of that individual unit. The individual IBR will also have protection algorithms within the control system to ensure the resource does not exceed its capabilities. Each IBR Generating Facility may have limiters implemented at the point of interconnection (POI) through its plant level control system. In addition, the collector bus and GSU may have protection systems that correlate with the plant output capability. For this case, the limiters and protection systems must be coordinated all the way up to the POI to ensure reliable operation and comply with the requirements of PRC-019.

An entity should not use artificial capability limitations at the POI, such as TO/ISO contractual obligations, for PRC-019. An inverter's maximum output capability (MVA) should be used as a reference point for coordination purposes.

If an Inverter Based Resource (IBR) Generating Facility regulates voltage at the POI, via a plant controller, then the coordination should occur at the point of origin for voltage regulating control down to the individual IBR. This will consist of the in-service control functions (e.g. limiters, etc.) and protection functions of the plant controller at the POI down to the individual inverters. The in-service control functions mentioned include voltage, Q_{min} , Q_{max} , P_{max} , P_{min} , frequency, etc. The capability of the plant at an aggregate level may be considered within this coordination study. During Fault Ride-Through (FRT), the plant controller will transfer control to the individual inverters. Hence, it is important that an entity understand how the individual inverters will operate and coordinate.

Some entities may regulate voltage solely at the inverter level and have reactive compensating devices connected to the collector bus. Note 1 from PRC-019 clarifies the voltage regulating system controls and states the following:

- 1 Limiters or protection functions that are installed and activated on the generator or synchronous condenser.

These reactive compensating devices are not integrated into the inverter control system; they are in place to support the system voltage but have no direct effect on the output power of an individual inverter. Hence, these reactive compensating devices are excluded from the requirements of PRC-019 since they are external to the generator control system.

If the voltage is regulated through a plant controller with reactive compensating devices connected to the collector bus, then these devices are integrated into the control system of the plant. The reactive power output of the reactive compensating device is a voltage source behind the point of voltage regulation and inherent to the voltage control system. The terminals of the IBR generating facility will now have a voltage source and current sources contributing to grid level voltage support. The plant controller will use the system voltage, which is now a function of this reactive power input, to send reference commands to individual inverters within the collector system. Therefore, an entity must ensure that the reactive compensating device protection scheme coordinates with the capabilities of the plant.

If control functions and protection functions are performed within the same device, then they may have identical set-points. The reasoning behind this is that both functions will experience the same potential errors since they are within the same controller and are receiving the same source inputs. However, the protection function must have a time delay to allow the control function margin to operate. This time delay margin should be long enough to allow the control action to reduce the parameter (i.e. voltage, current, etc.) before tripping occurs. The manufacturer may be consulted for control time delays and good engineering judgment should be applied.

For the purposes of power system protection and control evaluations, inverter-based resources have three operational statuses: On-line, Offline (tripped), and Momentary Cessation. This third operational status, momentary cessation, deviates from the traditional norms for utility scale power generation. From the vantage point of power system reliability, tripping an inverter and turning off an inverter's output can have the same detrimental impacts to reliability. Fundamentally, tripping an inverter and turning off an inverter output are the same concept, particularly from the vantage point of power system reliability. Therefore, it is recommended for entities to treat momentary cessation and tripping an inverter as the same action for PRC-019. This recommendation is consistent with guidance provided in NERC ERO Enterprise CMEP Practice Guide: Information to be Considered by CMEP Staff Regarding Inverter-Based Resources².

An entity may remove (disable) the momentary cessation function from the inverter programming to comply with the requirements of the standard. For inverters that are not capable of removing the functionality, an entity may program their momentary cessation functionality to the lowest voltage magnitude (for undervoltage conditions) and the highest voltage magnitude (for overvoltage conditions) the inverter is capable of withstanding to ensure the coordination required in PRC-019. This will allow the resource to provide as much support as possible for system abnormalities and achieve coordination with equipment capability.

Inverter Based Resource forms of generation are evolving and have great potential for further advancements. With that, these sources experience periodic firmware upgrades, similar to firmware upgrades required for microprocessor relays. When a plant controller or IBR unit control system firmware is upgraded, an entity should verify that the coordination requirements in R1 are intact to determine if a coordination analysis is required per R2 of the standard. Both the plant controller and the individual inverters have built-in control systems that can operate in different modes. The plant controller can operate in the following modes:

- **Voltage Control Mode:** The plant controller regulates the voltage at the POI to a voltage setpoint, by increasing or decreasing plant reactive power output.
- **Power Factor Control Mode:** The plant controller maintains power factor at the POI to a power factor setpoint, by increasing or decreasing plant reactive power output.

The IBR may receive a power limit, an active power reference, reactive power reference, power factor reference from the plant controller, or voltage reference that meets the objective as defined at POI level. Each inverter can operate in the following modes:

- **Voltage Control:** In this mode, the IBR regulates to a voltage setpoint, measured at its terminals, by increasing or decreasing reactive power output.
- **Reactive Power (Var) Control:** In this mode the resource receives a Var reference from the plant controller and provides the commanded Vars.
- **Power Factor Control:** In this mode the resource receives a power factor reference from the plant controller and provides power based on the commanded power factor.

² Reference CMEP Practice Guide

https://www.nerc.com/pa/comp/guidance/CMEPPPracticeGuidesDL/CMEP%20Practice%20Guide%20Information%20to%20be%20Considered%20by%20CMEP%20Staff%20Regarding%20Inverter-Based%20Resources_V1.1.pdf

In addition to the above operational control modes, during FRT mode the resources can be set to operate in reactive power priority (Q-priority) or in active power priority (P-priority). In the Q-priority mode, the resource prioritizes reactive power production over real power. It provides the Vars and uses the balance of the resource's KVA capability and real power availability to provide real power (or limits real power if in the power factor mode). In the P-priority mode, the resource prioritizes active power over reactive power. It outputs the maximum amount of real power available and can provide the balance of KVA capability (if any) to satisfy the Var commanded from the plant controller.

Synchronous Condensers

A synchronous condenser is a synchronous machine that contains an excitation system but does not have a mechanical input power system (i.e. prime mover, boiler, etc.). This machine is typically used to boost system voltage via the output of Vars or lower system voltage via the absorption of Vars. The synchronous condenser cannot produce real power since it does not have a prime mover. To the contrary, the machine will absorb a small amount of real power from the system due to windage losses, transients, etc. This drastically reduces the operating region in a typical GCC. However, the synchronous condenser operates in the same manner as a traditional synchronous generator in terms of voltage regulation and the associated control systems. Therefore, a synchronous condenser may use an implementation methodology similar to a synchronous generator for the purposes of PRC-019.

To illustrate coordination, an entity may mimic a very small amount of real power absorption, creating lines that depict the characteristics of each system component. This provides a visual for both engineering implementation and compliance evidence. Some OEM's provide capability curves for synchronous condensers that are similar to synchronous generation capability curves (D-curves, etc.). Therefore, an entity may display the entire generator capability curve and associated coordination curves in the positive real power quadrant. This approach is essentially identical to the methodology of a synchronous generator. Either one of these methodologies are sufficient evidence for evaluation of compliance with the standard.

Blackstart Generators

Blackstart units are any generation resources an entity uses to bring a unit on-line or support plant station service during start-up. For the purposes of PRC-019, a blackstart generator is any unit that is material to and designated as part of a Transmission Operator's restoration plant. During normal generator operation, station service is typically fed from the generator terminal via auxiliary transformers. However, during a full plant outage, an external source (either the transmission grid or a smaller generator) is required to provide the auxiliary power necessary to bring a unit on-line. A black start unit may be either a synchronous source or a dispersed power producing resource, depending on the design of the plant³. The type of unit determines the methodology an entity may use to demonstrate compliance with PRC-019. An entity may refer to the sections of this guideline that align with the type of unit.

Steady-State Stability Limit (SSSL)

The classical SSSL methodology portrayed in PRC-019 assumes the generator is supplied with a fixed excitation (the internal voltage behind the generator impedance) based on the nameplate rating of the machine. This methodology represents the manual SSSL, or the expected machine reaction given the voltage regulator is in the manual operation mode. Calculating the dynamic SSSL, with the voltage regulator in automatic mode, requires determining the relationship between a specific power output and power transfer angle (δ). This angle is defined as the angle between the generator internal voltage and the system voltage. Determining this relationship requires nonlinear equations and is a complicated task. Furthermore, use of the manual SSSL is the most conservative condition for coordination purposes. Therefore, even though the standard specifically instructs an entity to assume the voltage regulator is in automatic mode, it also allows the use of the manual SSSL for coordination purposes.

³ If it is designated as part of a Transmission Owner's restoration plant, per 4.2.4.

Per “Protective Relaying for Power Generation Systems” (see references in PRC-019), excitation limiters are typically set to coordinate with the manual SSSL. This approach normally provides the most restrictive operational scenario for coordination since the dynamic SSSL (voltage regulator is in automatic mode) typically provides the operator with more margin to absorb reactive power. Therefore, the Under-Excitation Limiter (UEL) is typically responsible for preventing an entity from operating in a region defined by the manual SSSL; this is not the protection schemes responsibility.

The industry norm has been to set protection systems based on the characteristics of the machine. An entity typically uses a loss of field (40) protection scheme to prevent thermal damage associated with absorbing an excessive amount of reactive power. The setting philosophy for this scheme has been solely based on the internal impedance of the generator. By using the generator impedance setting philosophy, the loss of field impedance characteristic will end up plotting just outside the GCC. This is especially true when plotting a negative-offset dual mho scheme in the P-Q plane. This is because the apparent impedance swing from the relays perspective will vary depending on the pre-contingency system load and will exceed the leading Var boundary of the GCC. Hence, the characteristic plot of this protection system will coordinate with the generator capability for a complete loss of excitation (as long as acceptable time delays are applied) but may not coordinate with the manual SSSL. The coordination between the loss of field scheme and SSSL is ultimately up to the desire of the entity and may or may not be adjusted to include the SSSL.

Modifying the system impedance will alter the resultant manual SSSL curve characteristic of a synchronous generator. An entity may conservatively determine this limit by utilizing a weak system configuration in their analysis. A weak system may be established by increasing the transfer impedance of the generator; the larger the system impedance the weaker the system will be able to respond to reactive power transients. The removal of adjacent generation will also reduce the strength of the system. It is good industry practice to remove an adjacent generator and implement the most critical transmission contingency scenario to create a “weak system” condition. An entity may then use a power flow/short circuit software to create a Thevenin equivalent (boundary equivalent) at the high-voltage side of the generator step-up transformer. This equivalent impedance may be used as a portion of X_5 to provide an accurate representation of a weak system in the SSSL calculation; the GSU impedance will provide the remaining portion of X_5 .

Historically, steady state stability has been a topic centered on synchronous machines. The stability limit identified in requirement 1.1.2 is defined as an angular stability limit. IBR units do not fit the traditional derivation of steady state stability. Therefore, the methodology for establishing the manual SSSL does not apply to IBR units.

Equipment or Protection System Changes

For equipment or protection system changes that have an impact on coordination, the entity should perform the new coordination analysis before putting a generating unit back into service. For example, the replacement of an excitation system or generator relay requires an entity to ensure proper coordination with limiters and equipment capabilities before putting the machine back on-line. Without this verification, a generation unit can be tied back into the grid and become susceptible to damage, misoperations, and system stability issues.

Chapter 2: Coordination Validation

This document demonstrates example methodologies an entity may use to validate coordination between generator control and protection systems. The first example method demonstrates coordination for a synchronous generation unit. This method identifies protection and limiter characteristic curves for the voltage control system and the generator protection system. These plots include stator overexcitation (V/Hz), field winding overexcitation, and generator underexcitation. The second example method demonstrates coordination for a synchronous condenser. This methodology closely resembles the methodology outlined for a synchronous generator. The third example method demonstrates coordination from an IBR generating facility point of interconnection down to the IBR level.

Chapter 3: Example Calculations

Synchronous Generation Example

Properly documented, the following calculations may be used to demonstrate compliance for this specific example. Different generator designs and protection schemes may require modifications to the calculations. An entity should not blindly copy the methodology outlined below; but should have an in-depth understanding of its holistic generation system before making specific coordination decisions. The one-line diagram for the synchronous generator example calculation is shown in **Figure 3.1** and the system parameters are shown below in **Table 3.1**.

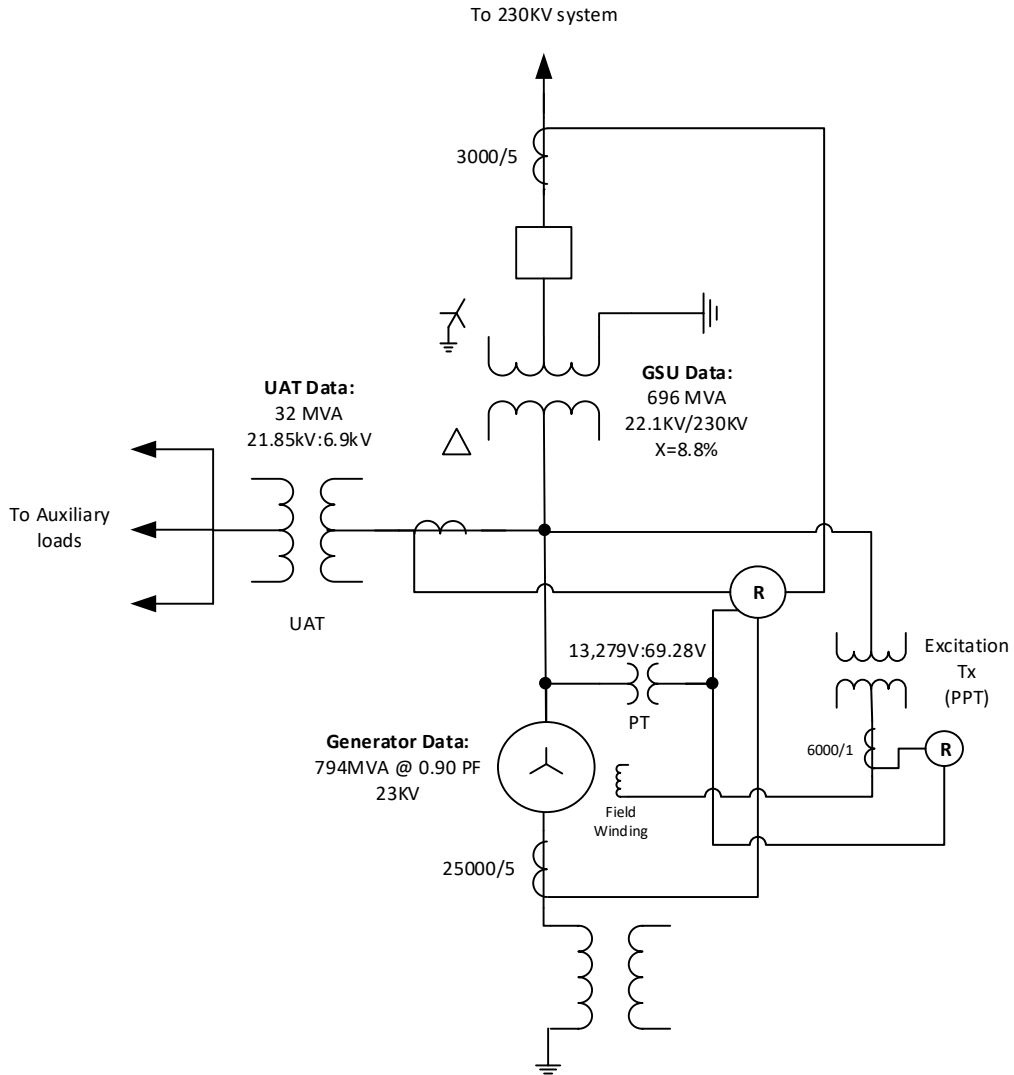

Figure 3.1: Synchronous Generator Sample System

Table 3.1: Synchronous Generator System Parameters Example Calculations	
Generator Input Descriptions	Input Values
Synchronous Generator nameplate (MVA @ rated pf):	$MVA_{GEN} = 794 \text{ MVA}$
	$PF_{GEN} = 0.90$
Generator rated voltage (Line-to-Line):	$V_{Gen} = 23 \text{ kV}$

Table 3.1: Synchronous Generator System Parameters Example Calculations

Direct Axis Subtransient Reactance, per unit:	$X''_d = 18.4\%$
Direct Axis Transient Reactance, per unit:	$X'_{di} = 30\%$
Direct Axis Synchronous Reactance, per unit:	$X_d = 181\%$
Generator Base Impedance:	$Z_{G_Base} = \frac{V_{gen}^2}{MVA_{GEN}} = 0.666\Omega$
Generator Current transformer (CT) ratio:	$CTR_{Gen} = \frac{25000}{5} = 5000$
Generator Potential transformer (PT) ratio:	$PTR_{Gen} = \frac{13279}{69.28} = 191.67$
Primary to Secondary Impedance Ratio:	$ZTR = \frac{CTR_{Gen}}{PTR_{Gen}} = 26.086$
Nominal relay (secondary) voltage:	$V_{Gen_nom} = \frac{V_{Gen}}{PTR_{Gen}} = 120$
Nominal relay (secondary) current:	$I_{Gen_nom} = \frac{MVA_{GEN}}{(\sqrt{3} \times V_{Gen} \times CTR_{Gen})}$
Generator Step-Up (GSU) Transformer Input Descriptions	Input Values
Generator step-up (GSU) transformer rating:	$MVA_{GSU} = 696 \text{ MVA}$
GSU transformer reactance (696 MVA base):	$X_{GSU_TBASE} = 8.8\%$
GSU transformer MVA base:	$MVA_{GSU_Base} = 696 \text{ MVA}$
GSU Transformer High-side Nameplate Voltage	$V_{GSU_HS} = 230 \text{ kV}$
GSU Transformer Low-side Nameplate Voltage	$V_{GSU_LS} = 22.1 \text{ kV}$
GSU transformer high-side no-load tap Voltage	$V_{GSU_HS_TAP} = 235 \text{ kV}$
GSU transformer turns ratio:	$GSU_{ratio} = \frac{V_{GSU_HS}}{V_{GSU_LS}}$
High-side nominal system voltage (Line-to-Line):	$V_{sys_nom} = 230 \text{ kV}$
GSU Current transformer (CT) ratio:	$CTR_{GSU} = \frac{3000}{5}$
Unit Auxiliary Transformer (UAT) Input Descriptions	Input Values
UAT nameplate MVA Base:	$MVA_{UAT_Base} = 32 \text{ MVA}$
UAT high-side nameplate voltage:	$V_{UAT_HS} = 21.85 \text{ kV}$
UAT low-side nameplate voltage:	$V_{UAT_LS} = 6.9 \text{ kV}$
Bulk Electric System Descriptions	Input Values

Table 3.1: Synchronous Generator System Parameters Example Calculations

System Base MVA:	$MVA_S = 100 \text{ MVA}$
System Base Voltage:	$V_S = 230 \text{ kV}$

Manual Steady State Stability Limit (SSSL):

To calculate the manual SSSL, an entity must determine the system impedance (transfer impedance) from the vantage point of the generator. In order to identify this impedance, define a configuration that will create a minimum generation/weak system condition. For this example, we removed the largest transmission line in the switchyard and the largest adjacent generator within the facility. The resultant equivalent impedance will represent a portion of the total system impedance to use in the SSSL calculations.

The system impedance at minimum generation/weak system (per short circuit program):

$$\text{Eq. (1)} \quad Z_{Weak_pu} = 0.00094 + j0.01086$$

Convert the weak system impedance to the transformer base:

$$\begin{aligned} \text{Eq. (2)} \quad Z_{W_TxBase_pu} &= \left(\frac{MVA_{GSU_Base}}{MVA_S} \right) \times \left(\frac{V_S^2}{V_{GSU_HS_TAP}^2} \right) \times Z_{Weak_pu} \\ Z_{W_TxBase_pu} &= \left(\frac{696 \text{ MVA}}{100 \text{ MVA}} \right) \times \left(\frac{230 \text{ kV}^2}{235 \text{ kV}^2} \right) \times (0.00094 + j0.01086) \\ Z_{W_TxBase_pu} &= 0.006 + j0.072 \end{aligned}$$

Convert the transformer base weak system impedance to the generator base:

$$\begin{aligned} \text{Eq. (3)} \quad Z_{W_Gbase_pu} &= \left(\frac{MVA_{Gen}}{MVA_{GSU_Base}} \right) \times \left(\frac{V_{GSU_LS}^2}{V_{Gen}^2} \right) \times Z_{W_TxBase_pu} \\ Z_{W_Gbase_pu} &= \left(\frac{794 \text{ MVA}}{696 \text{ MVA}} \right) \times \left(\frac{22.1 \text{ kV}^2}{23 \text{ kV}^2} \right) \times (0.006 + j0.072) \\ Z_{W_Gbase_pu} &= 0.007 + j0.076 \end{aligned}$$

$$\begin{aligned} \text{Eq. (4)} \quad Z_W &= Z_{W_pu} \times Z_{G_Base} \\ Z_W &= (0.007 + j0.076) \times 0.666 \Omega \\ Z_W &= (0.004 + j0.051) \Omega \end{aligned}$$

The total system impedance will consist of the equivalent minimum generation/weak system impedance and the transformer impedance. The transformer impedance may be defined on the transformer nameplate or OEM test reports.

Convert the GSU transformer impedance to the generator base:

$$\text{Eq. (5)} \quad X_{GSU_Gbase_pu} = \left(\frac{MVA_{Gen}}{MVA_{GSU_Base}} \right) \times \left(\frac{V_{GSU_LS}^2}{V_{Gen}^2} \right) \times X_{GSU_TBASE}$$

$$X_{GSU_Gbase_pu} = \left(\frac{794MVA}{696MVA} \right) \times \left(\frac{22.1kV^2}{23kV^2} \right) \times (j0.088)$$

$$X_{GSU_Gbase_pu} = j0.093$$

$$\text{Eq. (6)} \quad X_{GSU_Gbase} = X_{GSU_Gbase_pu} \times Z_{G_Base}$$

$$X_{GSU_Gbase} = j0.093 \times 0.666\Omega$$

$$X_{GSU_Gbase} = j0.062\Omega$$

Total System Impedance for Weak System Conditions (Per IEEE C37.102):

$$\text{Eq. (7)} \quad Z_{S_pu} = X_{GSU_GBase_pu} + Z_{W_Gbase_pu}$$

$$Z_{S_pu} = j0.093 + (0.007 + j0.076)$$

$$Z_{S_pu} = 0.007 + j0.169$$

$$\text{Eq. (8)} \quad Z_S = Z_{S_pu} \times Z_{G_Base}$$

$$Z_S = (0.007 + j0.169) \times 0.666\Omega$$

$$Z_S = (0.004 + j0.113) \Omega$$

$$\text{Eq. (9)} \quad X_S = \text{Im}(Z_S)$$

$$X_S = j0.113\Omega$$

Convert Total System Impedance for Weak System Conditions to secondary (relay) ohms:

$$\text{Eq. (10)} \quad Z_{S_sec} = Z_S \times \frac{CTR_{Gen}}{PTR_{Gen}}$$

$$Z_{S_sec} = (0.004 + j0.113) \Omega \times \frac{5000}{191.67}$$

$$Z_{S_sec} = (0.115 + j2.936) \Omega$$

$$\text{Eq. (11)} \quad X_{S_sec} = \text{Im}(Z_{S_sec})$$

$$X_{S_sec} = j2.936 \Omega$$

Convert the generator steady state (Synchronous) Impedance to secondary ohms:

$$\text{Eq. (12)} \quad X_{d_G} = X_d \times Z_{G_Base}$$

$$X_{d_G} = j1.81 \times 0.666 \Omega$$

$$X_{d_G} = j1.206 \Omega$$

$$\text{Eq. (13)} \quad X_{d_G_sec} = X_{d_G} \times \frac{CTR_{Gen}}{PTR_{Gen}}$$

$$X_{d_G_sec} = j1.206 \times \frac{5000}{191.67}$$

$$X_{d_G_sec} = j31.458 \Omega$$

Steady State Stability Limit (SSSL) Characteristic Plot in R-X Plane:

The Center Offset in the R-X plane is defined by:

$$\text{Eq. (14)}^4 \quad c_{RX} = -\left(\frac{1}{2}\right) \times |X_{d_G_sec} - X_{S_sec}|$$

$$c_{RX} = -\left(\frac{1}{2}\right) \times |j31.458 \Omega - j2.936 \Omega|$$

$$c_{RX} = -14.261 \Omega$$

The radius in the R-X plane is defined by:

$$\text{Eq. (15)}^4 \quad r_{RX} = \left(\frac{1}{2}\right) \times |X_{d_G_sec} + X_{S_sec}|$$

$$r_{RX} = \left(\frac{1}{2}\right) \times |j31.458 \Omega + j2.936 \Omega|$$

$$r_{RX} = 17.197 \Omega$$

⁴ See IEEE Std C37.102 Guide for AC Generator Protection

Use the following equations to create the characteristic curve of the SSSL in the R-X plane:

$$\text{Eq. (16)} \quad R_{SSSL} = r_{RX} \cos \theta$$

$$\text{Eq. (17)} \quad X_{SSSL} = r_{RX} \sin \theta + c_{RX}$$

Steady State Stability Limit (SSSL) Characteristic Plot in P-Q Plane:

Using a 0.95 per unit voltage magnitude will define the most limiting SSSL curve for coordination purposes.

The Center Offset in the P-Q plane is defined by:

$$\begin{aligned} \text{Eq. (18)}^5 \quad c_{PQ} &= -\left(\frac{1}{2}\right) \times (0.95V_{Gen})^2 \times \left(\frac{1}{|X_{d_G}|} - \frac{1}{|X_S|}\right) \\ c_{PQ} &= -\left(\frac{1}{2}\right) \times (0.95 \times 23kV)^2 \times \left(\frac{1}{|j1.206\Omega|} - \frac{1}{|j0.113\Omega|}\right) \\ c_{PQ} &= 1922.772 \text{ MVAR} \end{aligned}$$

The Radius in the P-Q plane is defined by:

$$\begin{aligned} \text{Eq. (19)}^5 \quad r_{PQ} &= \left(\frac{1}{2}\right) \times (0.95V_{Gen})^2 \times \left(\frac{1}{|X_{d_G}|} + \frac{1}{|X_S|}\right) \\ r_{PQ} &= \left(\frac{1}{2}\right) \times (0.95 \times 23kV)^2 \times \left(\frac{1}{|j1.206\Omega|} + \frac{1}{|j0.113\Omega|}\right) \\ r_{PQ} &= 2318.675 \text{ MVA} \end{aligned}$$

Use the following equations to create the characteristic curve of the SSSL in the P-Q plane:

$$\text{Eq. (20)} \quad P_{SSSL} = r_{PQ} \cos \theta$$

$$\text{Eq. (21)} \quad Q_{SSSL} = r_{PQ} \sin \theta + c_{PQ}$$

Table 3.2 contains the plot points on the R-X and P-Q planes for the manual steady state stability limit.

Table 3.2: Plot points on the R-X and P-Q planes for the Manual Steady State Limit				
θ	$R_{SSSL} (\Omega)$	$X_{SSSL} (\Omega)$	$P_{SSSL_min} (MW)$	$Q_{SSSL_min} (MVAR)$
90°	0	2.9	0	4241.4
80°	2.986	2.7	402.634	4206.2
70°	5.882	1.9	793.034	4101.6
60°	8.598	0.6	1159.337	3930.8
50°	11.054	-1.1	1490.415	3699.0
40°	13.174	-3.2	1776.208	3413.2
30°	14.893	-5.7	2008.031	3082.1
20°	16.16	-8.4	2178.842	2715.8

⁵ See IEEE Std C37.102 Guide for AC Generator Protection

Table 3.2: Plot points on the R-X and P-Q planes for the Manual Steady State Limit				
θ	$R_{SSSL} (\Omega)$	$X_{SSSL} (\Omega)$	$P_{SSSL_min} (MW)$	$Q_{SSSL_min} (MVAR)$
10°	16.936	-11.3	2283.449	2325.4
0°	17.197	-14.3	2318.675	1922.8
-10°	16.936	-17.2	2283.449	1520.1
-20°	16.16	-20.1	2178.842	1129.7
-30°	14.893	-22.9	2008.031	763.4
-40°	13.174	-25.3	1776.208	432.4
-50°	11.054	-27.4	1490.415	146.6
-60°	8.598	-29.2	1159.337	-85.3
-70°	5.882	-30.4	793.034	-256.1
-80°	2.986	-31.2	402.634	-360.7
-90°	0	-31.5	0	-395.9

Analysis of Generator Capability

The Generator Capability Curve (GCC) is typically provided by the manufacturer. The GCC may be represented in either the P-Q plane or the R-X plane or both.

Generator Capability Curve

The Generator Capability Curve (GCC) may be obtained from the generator manufacturer. The plot is typically provided on a P-Q axis. An entity can use the equation below to convert this curve to the R-X plane.

Convert P-Q to nominal R-X:

$$\text{Eq. (22)} \quad Z_{pf_Nom_Mag} = \left(\frac{V_S^2}{MVA_{pf}} \right) \times \left(\frac{CTR_{Gen}}{PTR_{Gen}} \right)$$

$$\text{Eq. (23)} \quad Z_{pf_Nom} = Z_{pf_Nom_Mag} \times \cos(\theta_{pf}) + j[Z_{pf_Nom_Mag} \times \sin(\theta_{pf})]$$

The Generator Capability Curve is typically not valid (not accurate) for voltage levels below 0.95 per unit. Therefore, a minimum GCC curve can be established as the worst-case condition for coordination purposes.

Convert P-Q to minimum R-X:

$$\text{Eq. (24)} \quad Z_{pf_Min_Mag} = \left(\frac{(0.95V_S)^2}{MVA_{pf}} \right) \times \left(\frac{CTR_{Gen}}{PTR_{Gen}} \right)$$

$$\text{Eq. (25)} \quad Z_{pf_Min} = Z_{pf_Min_Mag} \times \cos(\theta_{pf}) + j[Z_{pf_Min_Mag} \times \sin(\theta_{pf})]$$

Table 3.3 contains the plot points on the P-Q and R-X planes for the generator capability curve. These points will be used to display generator underexcitation coordination. Therefore, only the underexcited (leading power factor) portion of the GCC will be shown.

Table 3.3: Plot Points on the P-Q and R-X Planes for the Generator Capability Curve					
$P_{Gen} (MW)$	$Q_{Gen} (MVAR)$	$R_{Nom} (\Omega)$	$X_{Nom} (\Omega)$	$R_{Min} (\Omega)$	$X_{Min} (\Omega)$
786.06	-95.28	17.301408	-2.09714	15.614520	-1.892669
778.12	-150.86	17.092272	-3.313808	15.425776	-2.990712
754.3	-246.14	16.534196	-5.395369	14.922112	-4.869321

Table 3.3: Plot Points on the P-Q and R-X Planes for the Generator Capability Curve					
P _{Gen} (MW)	Q _{Gen} (MVAR)	R _{Nom} (Ω)	X _{Nom} (Ω)	R _{Min} (Ω)	X _{Min} (Ω)
698.72	-381.12	15.221382	-8.302572	13.737297	-7.493071
698.72	-381.12	15.221382	-8.302572	13.737297	-7.493071
635.2	-385.09	15.886247	-9.631037	14.337338	-8.692011
595.5	-389.06	16.241014	-10.6108	14.657515	-9.576243
555.8	-391.442	16.596483	-11.68867	14.978326	-10.54902
516.1	-393.03	16.92376	-12.88809	15.273693	-11.63150
476.4	-396.206	17.123174	-14.24077	15.453665	-12.85230
436.7	-400.97	17.145469	-15.74266	15.473786	-14.20775
397	-404.94	17.035925	-17.37664	15.374922	-15.68242
357.3	-406.528	16.83229	-19.15141	15.191142	-17.28414
317.6	-410.498	16.270066	-21.02906	14.683734	-18.97873
277.9	-412.88	15.482356	-23.00236	13.972826	-20.75963
238.2	-416.85	14.260554	-24.95597	12.870150	-22.52276
198.5	-420.82	12.65292	-26.82419	11.419260	-24.20883
158.8	-422.408	10.760842	-28.62384	9.711659	-25.83301
119.1	-425.584	8.4152396	-30.07046	7.594754	-27.13859
79.4	-428.76	5.7626162	-31.11813	5.200761	-28.08411
47.64	-432.73	3.4687834	-31.50812	3.130577	-28.43607
43.67	-428.76	3.2444727	-31.85482	2.928137	-28.74898
35.73	-412.88	2.8708902	-33.17473	2.590978	-29.94020
31.76	-408.91	2.6054606	-33.5453	2.351428	-30.27464
23.82	-400.97	2.0373215	-34.29491	1.838683	-30.95116
19.85	-399.382	1.7131034	-34.46764	1.546076	-31.10704
15.88	-397	1.3881829	-34.70457	1.252835	-31.32088
7.94	-394.618	0.7033354	-34.95577	0.634760	-31.54758
0	-393.824	2.146E-15	-35.04042	0.000000	-31.62398

Generator Over Flux Capability Curve:

This curve represents the amount of V/Hz the stator winding can withstand; any level above this curve leaves the generator susceptible to damage via flux overspill onto non-laminated portions of the stator. The overexcitation capability curve for the generator may be represented in per-unit quantities from the base voltage at the generator terminal. This curve may be obtained from the generator OEM.

Table 3.4 contains the plot points for the generator over flux capability curve.

Table 3.4: Plot Points for the Generator Over Flux Capability Curve	
Gen_24 (pu)	Gen_24 _t (sec.)
1.06	10000
1.06	3775
1.07	767
1.08	265
1.09	143
1.10	89
1.12	45
1.14	26

Table 3.4: Plot Points for the Generator Over Flux Capability Curve	
Gen_24 (pu)	Gen_24 _t (sec.)
1.16	18.1
1.18	13
1.20	10
1.22	7.94
1.24	6.42
1.26	5.52
1.28	4.75
1.29	4.35
1.30	4.12

Generator Step-Up (GSU) Transformer Over Flux Capability Curve:

The overexcitation capability curve for the GSU may be obtained from the transformer OEM or test reports. This curve represents the V/Hz magnitudes the transformer core may be exposed to. If the GSU low voltage winding has a different base voltage than the generator terminal, then the curve should be converted to the generator base.

$$\text{Eq. (26)} \quad GSU_{24_{Gen_base}} = GSU_{24_{GSU_base}} \times \left(\frac{V_{GSU_LS}}{V_{Gen}} \right)$$

Table 3.5 contains the plot points for the GSU overexcitation capability curve on the generator base.

Table 3.5: Plot Points for the GSU Overexcitation Capability Curve on the Generator Base		
GSU_24 _{GSU_base} (pu)	GSU_24 _{Gen_base} (pu)	GSU_24 _t (sec.)
1.25	1.201	60000
1.27	1.22	6000
1.30	1.249	300
1.32	1.268	60
1.56	1.499	6
1.65	1.585	0.6

Unit Auxiliary Transformer (UAT) Over Flux Capability Curve:

The overexcitation capability curve for the UAT may be obtained from the transformer OEM or test reports. This curve represents the V/Hz magnitudes the transformer core may be exposed to. If the UAT high-voltage winding has a different base voltage than the generator terminal, then the curve should be converted to the generator base.

$$\text{Eq. (27)} \quad UAT_{24_{Gen_base}} = UAT_{24_{UAT_base}} \times \left(\frac{V_{UAT_HS}}{V_{Gen}} \right)$$

Table 3.6 contains the plot points for the UAT overexcitation capability curve on the generator base.

Table 3.6: Plot Points for the UAT Overexcitation Capability Curve on the Generator Base		
UAT_24 _{UAT_base} (pu)	UAT_24 _{Gen_base} (pu)	UAT_24 _t (sec.)
1.125	1.069	1500
1.15	1.092	390
1.20	1.14	66

Table 3.6: Plot Points for the UAT Overexcitation Capability Curve on the Generator Base		
UAT_24 _{UAT_base} (pu)	UAT_24 _{Gen_base} (pu)	UAT_24 _t (sec.)
1.25	1.188	27
1.30	1.235	17.40
1.35	1.282	12.60
1.40	1.33	9.6

Generator Field Winding Overexcitation Capability Curve:

The field winding capability represents the thermal overload rating (I^2t) of the field winding. This curve defines the magnitude of current the excitation system may inject into the field winding. Per IEEE C50.13 “Standard for Cylindrical-Rotor Synchronous Generators”, the permissible rotor currents for overexcitation are derived from the following equation:

$$\text{Eq. (28)} \quad T_{Field} = \frac{33.75}{(I_{Field})^2 - 1}$$

Table 3.7 contains the plot points for the field winding thermal capability curve.

Table 3.7: Plot Points for the Field Winding Thermal Capability Curve	
I _{Field} (pu)	T _{Field} (sec)
1.13	121.885
1.25	60
1.46	29.825
2.09	10.02

Analysis of Generator Voltage Control System

The excitation system limiter and/or trip element set points may be obtained from the excitation system OEM documentation. An entity may request these values in MW/MVAR units and R/X impedance units.

Excitation System Underexcitation Limiter (UEL)

The UEL will prevent the excitation control system from reducing the internal generator voltage beyond a level that would exceed the generators VAR absorption capability and the manual SSSL. The excitation system UEL may be obtained from the excitation system OEM or from field service/test reports. The UEL will coordinate with the protective functions within the excitation system and the Loss of Field relay element. It will also coordinate with the stator core-end capabilities. Therefore, the protection engineer and the excitation system engineer/technician must coordinate their set-points and schemes before the unit can be put in-service and serve grid load. The following example includes both P-Q and R-X values. For a given voltage control system, use the manufacturer provided information (either P-Q, R-X, or both).

Table 3.8 contains the plot points for the excitation system UEL in the P-Q and R-X plane.

Table 3.8: Plot Points for the Excitation System UEL in the P-Q and R-X Plane			
P _{AVR_UEL} (MW)	Q _{AVR_UEL} (MVAR)	R _{AVR_UEL} (Ω)	X _{AVR_UEL} (Ω)
0	-285		
20	-285	3.37	-48.19

Table 3.8: Plot Points for the Excitation System UEL in the P-Q and R-X Plane			
P_{AVR_UEL} (MW)	Q_{AVR_UEL} (MVAR)	R_{AVR_UEL} (Ω)	X_{AVR_UEL} (Ω)
103	-282	15.7	-43.14
230	-274	24.81	-29.57
316	-265	25.61	-21.49
406	-234	25.51	-14.73
529	-193	23.02	-8.28
684	-145	19.31	-4.1
762	-107	17.75	-2.49

Excitation System Field Winding Overexcitation Limiter (OEL)

The OEL will prevent the excitation system from exceeding field current beyond a magnitude that would exceed the field current thermal capability. The excitation system OEL may be obtained from the excitation system OEM or from field service/test reports. The OEL will coordinate with the protective functions within the excitation system and the relay protection scheme (50, 51, 49, etc.). It will also coordinate with the Generator Field Winding Capability curve. Therefore, the protection engineer and the excitation system engineer/technician must coordinate their set-points and schemes before the unit can be put in-service and serve grid load.

For this example, an inverse-time OEL was implemented using field current as an operating quantity.

Table 3.9 contains the plot points for the excitation system OEL.

Table 3.9: Plot Points for the Excitation System OEL	
I_{41_OEL} (pu)	$T_{I_{41_OEL}}$ (sec.)
1.0573	633.0
1.0676	315.0
1.0777	208.0
1.0850	140
1.1147	50.0
1.2477	24.0
1.3450	16.0
1.4447	13.0
1.5454	11.0
1.6958	9.0
1.7936	8
1.8941	7.0
1.9899	6.0
200.0	4.0
200.0	0.0

Excitation System Field Winding Overexcitation Protection (OEP)

The purpose of an OEP scheme is to initiate a generator trip, through the excitation system, for a condition in which the excitation system OEL fails to stop an increase in field current beyond its characteristic curve. The protection functions within an excitation system operate like a relay; therefore, one must treat it as a protection system for coordination purposes. The excitation system time overcurrent element will be set to coordinate with the thermal capability curve of the field winding, per IEEE C50.13 or OEM ratings. This scheme should also coordinate with the

excitation system OEL by allowing the OEL the opportunity to initiate action first. This thermal limit may be verified with the OEM to ensure an accurate curve is plotted.

This example used an inverse-time protective function with the nominal field current as an operating quantity. The nominal field current is based on the power potential transformer (PPT) and the load current the excitation system draws. This value may be acquired from the excitation system OEM or field service/test reports.

Nominal field current (I_{41_Nom}):

$$\text{Eq. (29)} \quad I_{41_Nom} = 0.864$$

Time Overcurrent Pickup:

$$\text{Eq. (30)} \quad OEP_P = 0.92 \text{ A}$$

$$OEP_P_{pu} = \frac{OEP_P}{I_{41_Nom}}$$

$$OEP_P_{pu} = \frac{0.92}{0.864}$$

$$OEP_P_{pu} = 1.065$$

Time Overcurrent Time Dial:

$$OEP_TD = 2.3$$

Time Overcurrent Curve:

$$OEP_{Curve} = \textit{Moderately Inverse}$$

Table 3.10 contains the plot points for the excitation system OEP.

Table 3.10: Plot Points for the Excitation System OEP	
I_{41_OEP} (pu)	$T_{I_{41_OEP}}$ (sec)
1.109	145.9
1.11	142.7
1.112	136.8
1.123	111.5
1.130	99.9
1.135	93
1.158	70.8
1.216	44.8
1.274	33.2
1.332	26.7
1.39	22.4
1.505	17.3
1.621	14.3
1.737	12.3

Table 3.10: Plot Points for the Excitation System OEP	
I_{41_OEP} (pu)	$T_{I_{41_OEP}}$ (sec)
1.969	9.8
2.316	7.8
2.895	6.1

Excitation System Stator Volts per Hertz Limiter

The purpose of this limiter is to prevent the excitation system from producing high magnitudes of terminal voltage when the prime mover is not operating at appropriate speeds. The intent is to prevent exposing the generator stator core and connected transformers from excessive magnetic flux. The excitation system V/Hz limiter will coordinate with the protective functions within the excitation system, and the relay protection scheme (24,59P). The limiter will also coordinate with the generator overexcitation capability curve. The set-point and curve characteristic may be obtained from the excitation system OEM or field service/test reports. This curve is on the generator base voltage since its voltage source comes from PT's at the terminal of the generator.

For this example, an inverse-time limiter function was implemented utilizing a V/Hz operating quantity.

Table 3.11 contains the plot points for the Excitation System Stator Overexcitation Limiter.

Table 3.11: Plot Points for the Excitation System Stator Overexcitation Limiter	
AVR_{24_Lim} (pu)	$T_{AVR_{24_Lim}}$ (sec.)
1.30	0.70
1.25	1.0
1.20	1.50
1.15	2.20
1.12	3.40
1.10	4.20
1.09	5.20
1.08	7.10
1.07	9.80
1.06	16.90
1.0537	62.0

Analysis of Protection Schemes

Protection schemes may be located within a protection system or the generator control system.

V/Hz Overexcitation Protection Scheme:

The generator V/Hz scheme will initiate a generator trip for a condition in which the excitation system V/Hz limiter fails to stop an increase in stator voltage, relative to frequency, beyond its characteristic curve. The V/Hz scheme will coordinate with the generator stator overexcitation capability curve. The scheme will also coordinate with the excitation system V/Hz limiter by allowing the limiter the opportunity to initiate action first. The V/Hz schemes associated with the excitation transformer or the GSU should align with the generator V/Hz scheme for the design provided in the example.

The Level 1 element will be used as a definite time element to initiate an alarm and identify an overexcitation condition. This will give the generator operator the opportunity to manually correct the abnormal overexcitation conditions.

Definite Time Level 1 Element:

$$24D1P = 105 \%$$

$$24D1D = 60 \text{ cycles}$$

The Level 2 element will be used as a definite time element to initiate a generate trip during high levels of V/Hz to prevent overexcitation damage. This set-point and time delay will coordinate with the overexcitation capabilities of the generator to prevent damage. This element will also allow enough margin for the excitation control system to correct the abnormal operating conditions before the relay initiates a trip.

Definite Time Level 2 Element:

$$24D2P2 = 128 \%$$

$$24D2D = 66 \text{ cycles} = 1.10 \text{ sec.}$$

The inverse time element will be used to initiate a generator trip for low to moderate overexcitation conditions. This curve characteristic will coordinate with the overexcitation capability of the generator to prevent damage. It will also allow enough margin for the excitation control system to correct the abnormal operating condition before the relay initiates a trip.

Inverse Time Pickup:

$$24IP = 106 \%$$

Inverse Time Dial:

$$24ITD = 1.5$$

Inverse Time Curve:

$$24IT_Curve = 1.0$$

Volts/Hz (24) Inverse Time Element Curve Characteristics:

$$\text{Eq. (31)} \quad T_{24_IT} = \frac{(0.003 * 24ITD)}{(V_{24_IT} - 1)^2} \text{ minutes}$$

Table 3.12 contains the calculations of the time delays for the inverse time curve characteristic.

Table 3.12: Calculations of Time Delays for the Inverse Time Curve Characteristics		
V_{24IT} (pu)	M_{24IT}	T_{24IT} (sec)
1.06	1	75
1.07	1.009	55.1
1.08	1.019	42.2
1.09	1.028	33.3
1.10	1.038	27
1.11	1.047	22.3
1.12	1.057	18.7
1.15	1.085	12
1.18	1.113	8.3
1.20	1.132	6.8
1.25	1.179	4.3
1.28	1.208	3.4

Table 3.13 contains the calculations of the time delays for the definite time element plot.

Table 3.13: Calculations of the Time Delays for the Definite Time Element Plot	
V_{24DT} (pu)	T_{24IT} (sec)
24D2P2	1.10
24D2P2	3.4

Field Winding Overcurrent (50/51) Overload Protection Scheme

The winding overcurrent scheme will initiate a generator trip for a condition in which the excitation system OEL fails to stop an increase in field current beyond its characteristic curve. The overcurrent element monitoring the excitation current will coordinate with the thermal capability of the field winding, per IEEE C50.13 or OEM ratings. The scheme will also coordinate with the excitation system OEL by allowing the limiter the opportunity to initiate action first.

Nominal field current (I_{41_Nom}):

$$I_{41_Nom} = 0.864$$

Time Overcurrent Pickup:

$$\text{Eq. (32)} \quad 51P = 0.92 A$$

$$51P_{pu} = \frac{51P}{I_{41_Nom}}$$

$$51P_{pu} = 1.065$$

Time Overcurrent Time Dial:

$$51TD = 12.3$$

Time Overcurrent Curve:

$$51P_{Curve} = U1$$

Time Overcurrent Curve Characteristics:

$$\text{Eq. (33)} \quad T_{51} = 51TD \times \left[0.0226 + \frac{0.0104}{(M_{51}^{0.02} - 1)} \right]$$

Table 3.14 contains the calculations of the curve characteristic for the time overcurrent element.

Table 3.14: Calculations of the Curve Characteristics for the Time Overcurrent Element		
I₅₁ (pu)	M₅₁	T₅₁ (sec)
1.109	1.041	157.5
1.11	1.042	154.1
1.112	1.044	147.7
1.123	1.055	120.4
1.130	1.061	107.9
1.135	1.066	100.4
1.158	1.088	76.5
1.216	1.142	48.4
1.274	1.196	35.9

Table 3.14: Calculations of the Curve Characteristics for the Time Overcurrent Element		
I_{51} (pu)	M_{51}	T_{51} (sec)
1.332	1.251	28.8
1.39	1.305	24.2
1.505	1.413	18.7
1.621	1.522	15.4
1.737	1.631	13.3
1.969	1.849	10.6
2.316	2.175	8.4
2.895	2.719	6.6

Generator Loss of Field (40) Protection Scheme

This example will use IEEE C37.102 method 1 for the loss of field (LOF) protection scheme. The level 1 element will detect loss of field conditions during heavier load conditions. This element may be plotted in either the P-Q plane or the R-X plane or both. This element does not have to coordinate with the curves identified within PRC-019 because it protects against severe slip frequency (pole slippage), in which the apparent impedance/power swing loci will overshoot the capability curve of the generator and has a very short time delay.

Zone 1 Diameter:

$$\text{Eq. (34)} \quad Z_{G_base_sec} = Z_{G_Base} \times ZTR$$

$$Z_{G_base_sec} = 0.666\Omega \times 26.086$$

$$Z_{G_base_sec} = 17.38$$

$$\text{Eq. (35)} \quad 40Z1P = \frac{V_{Gen_nom}}{(I_{Gen_nom} \times \sqrt{3})}j$$

$$40Z1P = \frac{119.997}{(3.986 \times \sqrt{3})}j$$

$$40Z1P = 17.38 \Omega$$

Zone 1 Offset:

$$\text{Eq. (36)} \quad X'_{d_act} = X'_{di} \times Z_{G_Base}$$

$$X'_{d_act} = j0.3 \times 0.666\Omega$$

$$X'_{d_act} = j0.2 \Omega$$

$$\text{Eq. (37)} \quad X'_{d_sec} = X'_{d_act} \times ZTR$$

$$X'_{d_sec} = j0.2\Omega \times 26.086$$

$$X'_{d_{sec}} = j5.214 \Omega$$

$$\begin{aligned} \text{Eq. (38)} \quad 40XD1 &= -\frac{X'_{d_{sec}}}{2} \\ 40XD1 &= -\frac{j5.214\Omega}{2} \\ 40XD1 &= -j2.607 \Omega \end{aligned}$$

Loss of Field Zone 1 (40) Plot in R-X Plane:

The Zone 1 Mho element center offset is equal to the radius of the element plus the offset of the element from the origin.

Center Offset:

$$\begin{aligned} \text{Eq. (39)} \quad c_{40_1_RX} &= -\left| -\left(\frac{40Z1P}{2}\right) + 40XD1 \right| \\ c_{40_1_RX} &= -\left| -\left(\frac{j17.38\Omega}{2}\right) + -j2.607\Omega \right| \\ c_{40_1_RX} &= -11.297 \Omega \end{aligned}$$

Center Radius:

$$\begin{aligned} \text{Eq. (40)} \quad r_{40_1_RX} &= \frac{|40Z1P|}{2} \\ r_{40_1_RX} &= \frac{|j17.38\Omega|}{2} \\ r_{40_1_RX} &= 8.69 \Omega \end{aligned}$$

An entity can use the equation below to plot this curve to the R-X plane.

$$\text{Eq. (41)} \quad R_{40_1} = r_{40_1_RX} \times \cos(\theta)$$

$$\text{Eq. (42)} \quad X_{40_1} = r_{40_1_RX} \times \sin(\theta) + c_{40_1_RX}$$

Loss of Field Zone 1 (40) Translation to P-Q Plane:

Zone 1 Offset (primary Ohms):

$$\begin{aligned} \text{Eq. (43)} \quad 40XD1_{pri} &= \frac{40XD1}{ZTR} \\ 40XD1_{pri} &= \frac{-j2.607\Omega}{26.086} \\ 40XD1_{pri} &= -j0.1 \Omega \end{aligned}$$

Maximum Mho reactance distance from origin:

$$\text{Eq. (44)} \quad 40MAX_{X_{sec}} = -(|40XD1| + |40Z1P|)$$

$$40MAX_{X_{sec}} = -(|-j2.607\Omega| + |j17.38\Omega|)$$

$$40MAX_{X_{sec}} = -19.987 \Omega$$

$$\text{Eq. (45)} \quad 40MAX_X = \frac{-19.987\Omega}{ZTR}$$

$$40MAX_X = \frac{40MAX_{X_{sec}}}{26.086}$$

$$40MAX_X = -0.766 \Omega$$

MVA of Offset Setting:

$$\text{Eq. (46)} \quad MVA_{40XD1} = \frac{(V_{Gen}^2)}{40XD1_{pri}}$$

$$MVA_{40XD1} = \frac{(23kV^2)}{-j0.1\Omega}$$

$$MVA_{40XD1} = j5293.333 \text{ MVA}$$

MVA of Maximum Reactance Distance from Origin:

$$\text{Eq. (47)} \quad MVA_{40Max} = \frac{(V_{Gen}^2)}{40MAX_X}$$

$$MVA_{40Max} = \frac{(23kV^2)}{-0.766\Omega}$$

$$MVA_{40Max} = -690.435 \text{ MVA}$$

In the P-Q plane the offset of the Mho circle will be represented by the MVA of the maximum Mho reactance from the origin, since this will produce a small MVA magnitude. The maximum distance of the Mho circle on the reactance axis, from the origin, will be equivalent to the MVA magnitude from the impedance offset setting.

Therefore, the diameter of the Mho Circle in the P-Q plane will equal:

$$\text{Eq. (48)} \quad 40Z1_{PQ} = |MVA_{40XD1}| - |MVA_{40Max}|$$

$$40Z1_{PQ} = |j5293.333 \text{ MVA}| - |-690.435 \text{ MVA}|$$

$$40Z1_{PQ} = 4602.899 \text{ MVA}$$

The radius of the Mho Circle in the P-Q plane will equal:

$$\text{Eq. (49)} \quad r_{40_1_PQ} = -\frac{40Z1_{PQ}}{2}$$

$$r_{40_1_PQ} = -\frac{4602.899 \text{ MVA}}{2}$$

$$r_{40_1_PQ} = 2301.499 \text{ MVA}$$

The center offset of the Mho Circle in the P-Q plane will equal:

$$\text{Eq. (50)} \quad c_{40_1_PQ} = MVA_{40Max} - r_{40_1_PQ}$$

$$c_{40_1_PQ} = -690.435 \text{ MVA} - 2301.499 \text{ MVA}$$

$$c_{40_1_PQ} = -2991.884 \text{ MVAR}$$

Use the following equations to create the characteristic curve for the loss of field element (40) in the P-Q plane:

$$\text{Eq. (51)} \quad P_{40_1} = r_{40_1_PQ} \times \cos(\theta)$$

$$\text{Eq. (52)} \quad Q_{40_1} = r_{40_1_PQ} \times \sin(\theta) + c_{40_1_PQ}$$

Table 3.15 contains the plot points on the R-X and P-Q planes for the Loss of Field #1 element.

Table 3.15: Plot Points on the R-X and P-Q Planes for the Loss of Field #1 Element				
θ	$R_{40_1} (\Omega)$	$X_{40_1} (\Omega)$	$P_{40_1} (\text{MW})$	$Q_{40_1} (\text{MVAR})$
90°	0	-2.6	0	-690.4
80°	1.509	-2.7	399.642	-725.4
70°	2.972	-3.1	787.142	-829.2
60°	4.345	-3.8	1150.725	-998.8
50°	5.586	-4.6	1479.343	-1228.9
40°	6.657	-5.7	1763.012	-1512.5
30°	7.526	-7.0	1993.114	-1841.2
20°	8.166	-8.3	2162.655	-2204.7
10°	8.558	-9.8	2266.485	-2692.2
0°	8.69	-11.3	2301.499	-2991.9
-10°	8.558	-12.8	2266.485	-3391.5
-20°	8.166	-14.3	2162.655	-3779
-30°	7.526	-15.6	1993.114	-4142.6
-40°	6.657	-16.9	1763.012	-4471.2
-50°	5.586	-18.0	1479.343	-4754.9
-60°	4.345	-18.8	1150.725	-4985
-70°	2.972	-19.5	787.142	-5154.5
-80°	1.509	-19.9	399.642	-5258.4
-90°	0	-20	0	-5293.3
-100°	-1.509	-19.9	-399.642	-5258.4
-110°	-2.972	-19.5	-787.142	-5154.5
-120°	-4.345	-18.8	-1150.725	-4985
-130°	-5.586	-18	-1479.343	-4754.9
-140°	-6.657	-16.9	-1763.012	-4471.2
-150°	-7.526	-15.6	-1993.114	-4142.6
-160°	-8.166	-14.3	-2162.655	-3779
-170°	-8.558	-12.8	-2266.485	-3391.5

Table 3.15: Plot Points on the R-X and P-Q Planes for the Loss of Field #1 Element				
θ	$R_{40_1} (\Omega)$	$X_{40_1} (\Omega)$	$P_{40_1} (MW)$	$Q_{40_1} (MVAR)$
-180°	-8.69	-11.3	-2301.449	-2991.9
-190°	-9.558	-9.8	-2266.485	-2592.2
-200°	-8.166	-8.3	-2162.655	-2204.7
-210°	-7.526	-7.0	-1993.114	-1841.2
-220°	-6.657	-5.7	-1763.012	-1512.5
-230°	-5.586	-4.6	-1479.343	-1228.9
-240°	-4.345	-3.8	-1150.725	-998.8
-250°	-2.972	-3.1	-787.142	-829.2
-260°	-1.509	-2.7	-399.642	-725.4
-270°	0	-2.6	0	-690.4

The level 2 element will protect against loss of field during lighter load conditions, where the lower slip frequency will cause higher characteristic impedances and lower asynchronous current magnitudes. This element may be plotted in either the P-Q plane or the R-X plane or both. For this example, this element will coordinate with the varying generator impedance characteristic during a complete loss of field scenario.

Zone 2 Diameter:

$$\begin{aligned} \text{Eq. (53)} \quad 40Z2P &= X_d \times Z_{G_Base} \times ZTR \\ 40Z2P &= j1.81 \times 0.666\Omega \times 26.086 \\ 40Z2P &= j31.458 \Omega \end{aligned}$$

Zone 2 Offset:

$$\begin{aligned} \text{Eq. (54)} \quad 40XD2 &= 40XD1 \\ 40XD2 &= -j2.607 \Omega \end{aligned}$$

Loss of Field Zone 2 (40) Plot in R-X Plane:

The Zone 2 Mho element center offset is equal to the radius of the element plus the offset of the element from the origin.

Center Offset:

$$\begin{aligned} \text{Eq. (55)} \quad c_{40_2_RX} &= - \left| - \left(\frac{40Z2P}{2} \right) + 40XD2 \right| \\ c_{40_2_RX} &= - \left| - \left(\frac{j31.458 \Omega}{2} \right) + -j2.607 \Omega \right| \\ c_{40_2_RX} &= -18.336 \Omega \end{aligned}$$

Center Radius:

$$\begin{aligned} \text{Eq. (56)} \quad r_{40_2_RX} &= \frac{|40Z2P|}{2} \\ r_{40_2_RX} &= \frac{|j31.458 \Omega|}{2} \\ r_{40_2_RX} &= 15.729 \Omega \end{aligned}$$

Use the following equations to create the characteristic curve for the loss of field element (40) in the P-Q plane:

$$\text{Eq. (57)} \quad R_{40_2} = r_{40_2_RX} \times \cos(\theta)$$

$$\text{Eq. (58)} \quad X_{40_2} = r_{40_2_RX} \times \sin(\theta) + c_{40_2_RX}$$

Loss of Field Zone 2 (40) Translation to P-Q Plane:

Zone 2 Offset (primary Ohms):

$$\begin{aligned} \text{Eq. (59)} \quad 40XD2_{pri} &= \frac{40XD2}{ZTR} \\ 40XD2_{pri} &= \frac{-j2.607 \Omega}{26.086} \\ 40XD2_{pri} &= -j0.1 \Omega \end{aligned}$$

Maximum Mho reactance distance from origin:

$$\begin{aligned} \text{Eq. (60)} \quad 40MAX_{X2_sec} &= -(|40XD2| + |40Z2P|) \\ 40MAX_{X2_sec} &= -(|-j2.607 \Omega| + |j31.458 \Omega|) \\ 40MAX_{X2_sec} &= -34.065 \Omega \end{aligned}$$

$$\begin{aligned} \text{Eq. (61)} \quad 40MAX_{X2} &= \frac{40MAX_{X2_sec}}{ZTR} \\ 40MAX_{X2} &= \frac{-34.065 \Omega}{26.086} \\ 40MAX_{X2} &= -1.306 \Omega \end{aligned}$$

MVA of Offset Setting:

$$\begin{aligned} \text{Eq. (62)} \quad MVA_{40XD2} &= \frac{(V_{Gen}^2)}{40XD2_{pri}} \\ MVA_{40XD2} &= \frac{(23kV^2)}{-j0.1 \Omega} \\ MVA_{40XD2} &= j5293.333 \text{ MVA} \end{aligned}$$

MVA of Maximum Reactance Distance from Origin:

$$\begin{aligned} \text{Eq. (63)} \quad MVA_{40Max_2} &= \frac{(V_{Gen}^2)}{40MAX_{X2}} \\ MVA_{40Max_2} &= \frac{(23kV^2)}{-1.306 \Omega} \\ MVA_{40Max_2} &= -405.102 \text{ MVA} \end{aligned}$$

In the P-Q plane the offset of the Mho circle will be represented by the MVA of the maximum Mho reactance from the origin, since this will produce a small MVA magnitude. The maximum distance of the Mho circle on the reactance axis, from the origin, will be equivalent to the MVA magnitude from the impedance offset setting.

Therefore, the diameter of the Mho Circle in the P-Q plane will equal:

$$\begin{aligned} \text{Eq. (64)} \quad 40Z2_{PQ} &= |MVA_{40XD2}| - |MVA_{40Max_2}| \\ 40Z2_{PQ} &= |j5293.333 \text{ MVA}| - |-405.102 \text{ MVA}| \\ 40Z2_{PQ} &= 4888.231 \text{ MVA} \end{aligned}$$

The radius of the Mho Circle in the P-Q plane will equal:

$$\begin{aligned} \text{Eq. (65)} \quad r_{40_2_PQ} &= \frac{40Z_{2_PQ}}{2} \\ r_{40_2_PQ} &= \frac{4888.231 \text{ MVA}}{2} \\ r_{40_2_PQ} &= 2444.116 \text{ MVA} \end{aligned}$$

The center offset of the Mho Circle in the P-Q plane will equal:

$$\begin{aligned} \text{Eq. (66)} \quad c_{40_2_PQ} &= MVA_{40_Max_2} - r_{40_2_PQ} \\ c_{40_2_PQ} &= -405.102 \text{ MVA} - 2444.116 \text{ MVA} \\ c_{40_2_PQ} &= -2849.218 \text{ MVAR} \end{aligned}$$

Use the following equations to create the characteristic curve for the loss of field element (40) in the P-Q plane:

$$\text{Eq. (67)} \quad P_{40_2} = r_{40_2_PQ} \times \cos(\theta)$$

$$\text{Eq. (68)} \quad Q_{40_2} = r_{40_2_PQ} \times \sin(\theta) + c_{40_2_PQ}$$

Table 3.16 contains the plot points on the R-X and P-Q planes for the Loss of Field #2 element.

Table 3.16: Plot Points on the R-X and P-Q Planes for the Loss of Field #2 Element				
θ	$R_{40_2} (\Omega)$	$X_{40_2} (\Omega)$	$P_{40_2} (\text{MW})$	$Q_{40_2} (\text{MVAR})$
90°	0	-2.6	0	-405.1
80°	2.731	-2.8	424.416	-442.2
70°	5.38	-3.6	835.937	-552.5
60°	7.864	-4.7	1222.058	-732.6
50°	10.11	-6.3	1571.047	-976.9
40°	12.049	-8.2	1872.301	-1278.2
30°	13.622	-10.5	2116.666	-1627.2
20°	14.78	-13	2296.717	-2013.3
10°	15.49	-15.6	2406.984	-2424.8
0°	15.729	-18.3	2444.116	-2849.2
-10°	15.49	-21.1	2406.984	-3273.6
-20°	14.78	-23.7	2296.717	-3685.2
-30°	13.622	-26.2	2116.666	-4071.3
-40°	12.049	-28.4	1872.301	-4420.3
-50°	10.11	-30.4	1571.047	-4721.5
-60°	7.864	-32	1222.058	-4965.9
-70°	5.38	-33.1	835.937	-5145.9
-80°	2.731	-33.8	424.416	-5256.2
-90°	0	-34.1	0	-5293.3
-100°	-2.731	-33.8	-424.416	-5256.2
-110°	-5.38	-33.1	-835.937	-5145.9
-120°	-7.864	-32	-1222.058	-4965.9
-130°	-10.11	-30.4	-1571.047	-4721.5
-140°	-12.049	-28.4	-1872.301	-4420.3

Table 3.16: Plot Points on the R-X and P-Q Planes for the Loss of Field #2 Element				
θ	$R_{40.2} (\Omega)$	$X_{40.2} (\Omega)$	$P_{40.2} (MW)$	$Q_{40.2} (MVAR)$
-150°	-13.622	-26.2	-2116.666	-4071.3
-160°	-14.78	-23.7	-2296.717	-3685.2
-170°	-15.49	-21.1	-2406.984	-3273.6
-180°	-15.729	-18.3	-2444.116	-2849.2
-190°	-15.49	-15.6	-2406.984	-2424.8
-200°	-14.78	-13	-2296.717	-2013.3
-210°	-13.622	-10.5	-2116.666	-1627.2
-220°	-12.049	-8.2	-1872.301	-1278.2
-230°	-10.11	-6.3	-1571.047	-976.9
-240°	-7.864	-4.7	-1222.058	-732.6
-250°	-5.38	-3.6	-835.937	-552.5
-260°	-2.731	-2.8	-424.416	-442.2
-270°	0	-2.6	0	-405.1

Coordination Plots/Diagrams for Compliance Evidence

The following graphs may be used as evidence to demonstrate compliance with the requirements of PRC-019. An entity may compile the information derived in the previous sections of this example to develop these coordination plots.

The stator overexcitation scheme ([Figure 3.2](#)) consists of excitation system V/Hz limiter coordination with relay and excitation system V/Hz protection. In addition, the illustration shows the coordination between the relay and excitation system V/Hz protection with the generator, GSU, and UAT overexcitation capability.

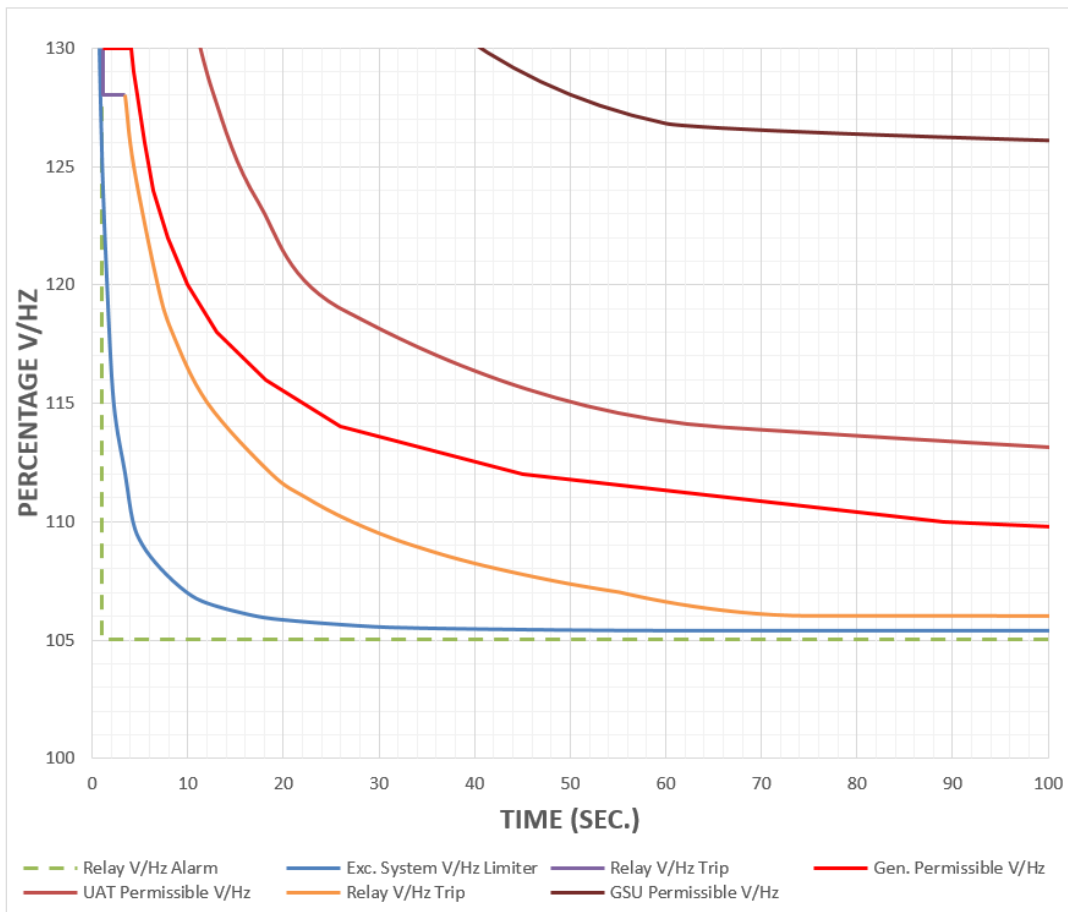

Figure 3.2: Synchronous Generator Stator Overflux Coordination

The generator field winding overexcitation scheme (Figure 3.3) consists of the excitation system limiter coordination with relay and excitation system protection. In addition, the illustration shows the coordination between the relay and excitation system OEP protection with the field winding thermal capability.

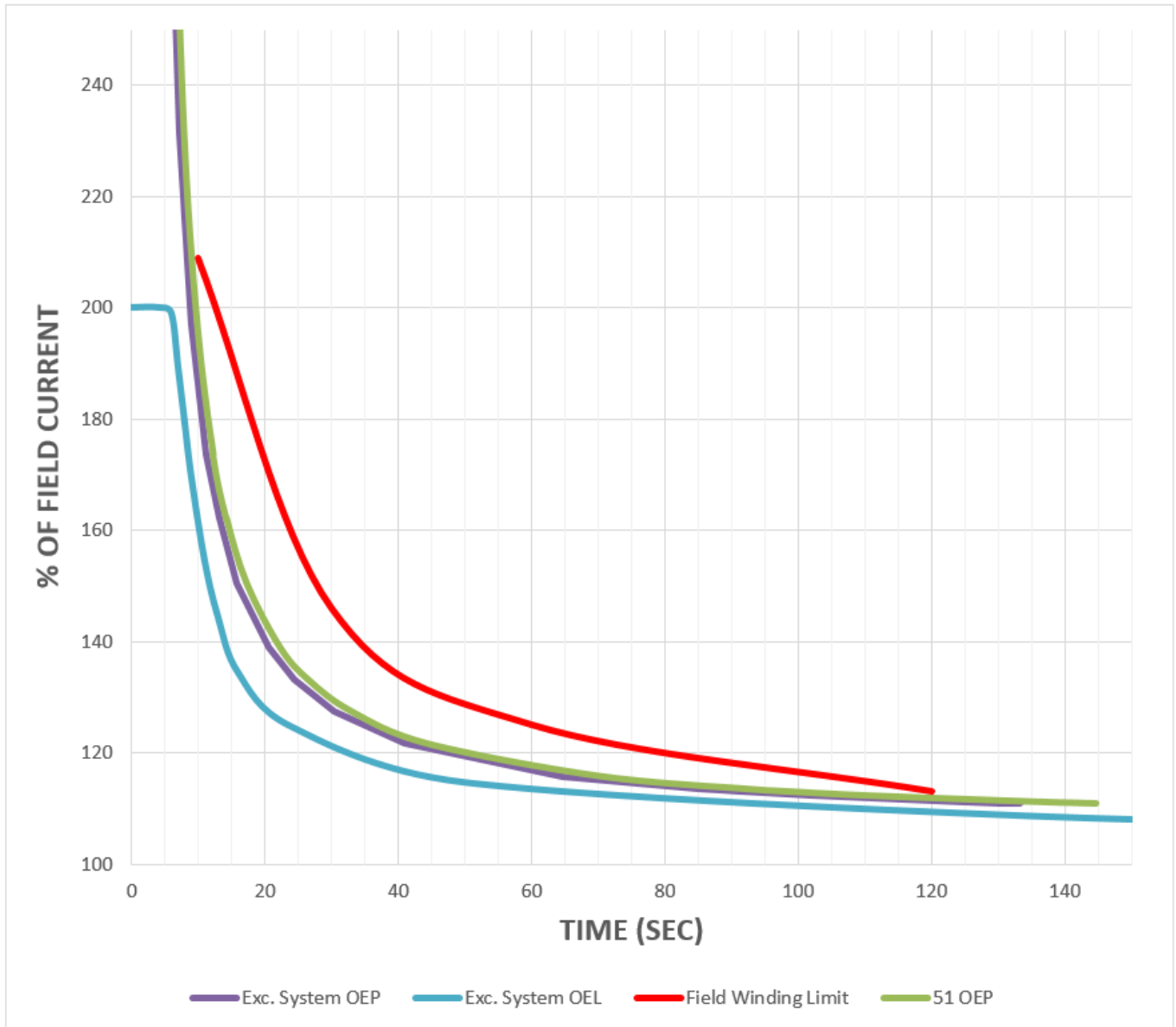

Figure 3.3: Synchronous Generator Overexcitation Coordination

The generator underexcitation scheme ([Figure 3.4](#) and [Figure 3.5](#)) consists of excitation system UEL coordination with loss of field protection. In addition, the illustration shows the coordination between the loss of field protection scheme with the stator end-winding thermal capability.

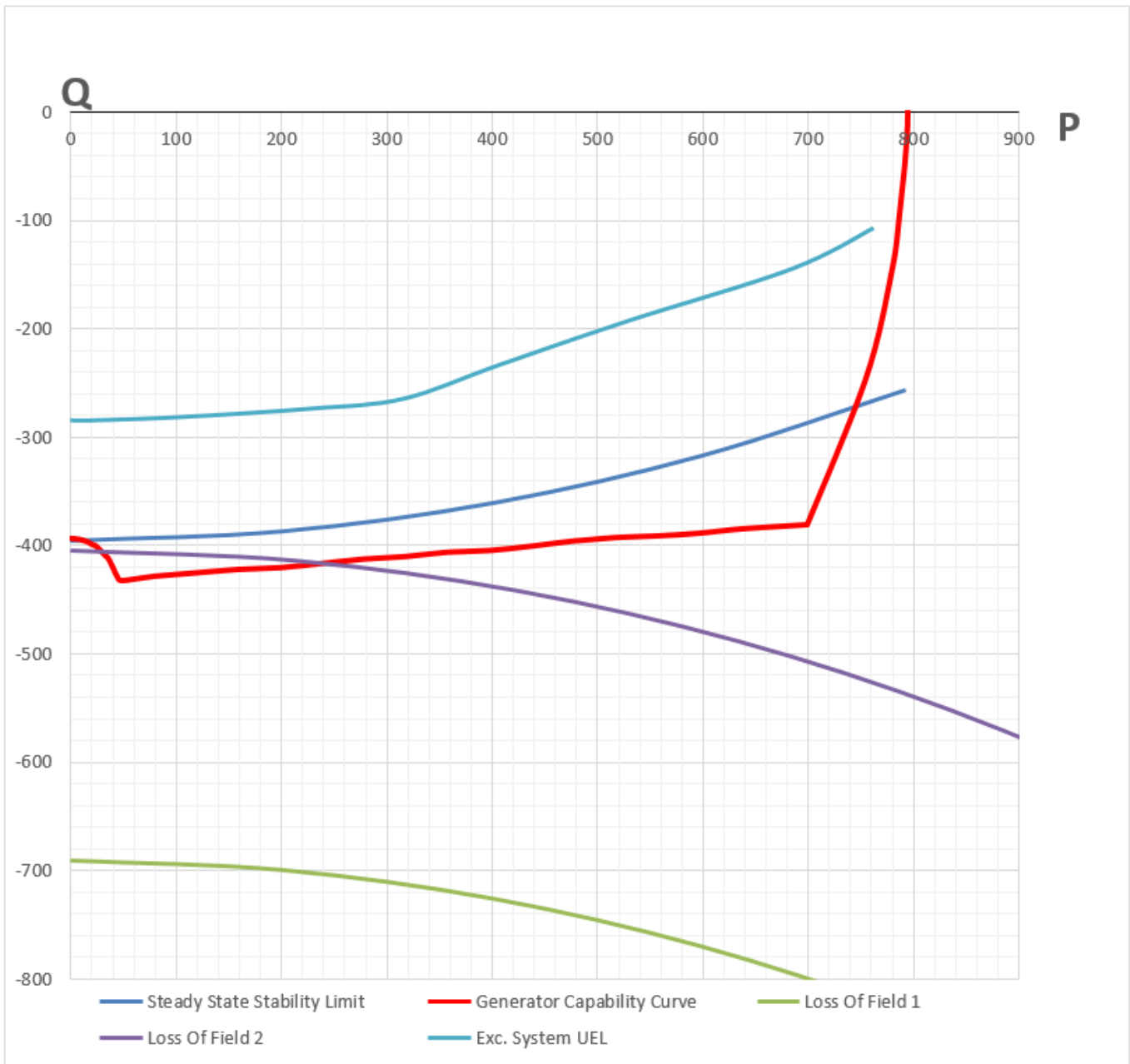

Figure 3.4: Synchronous Generator Underexcitation P-Q Coordination

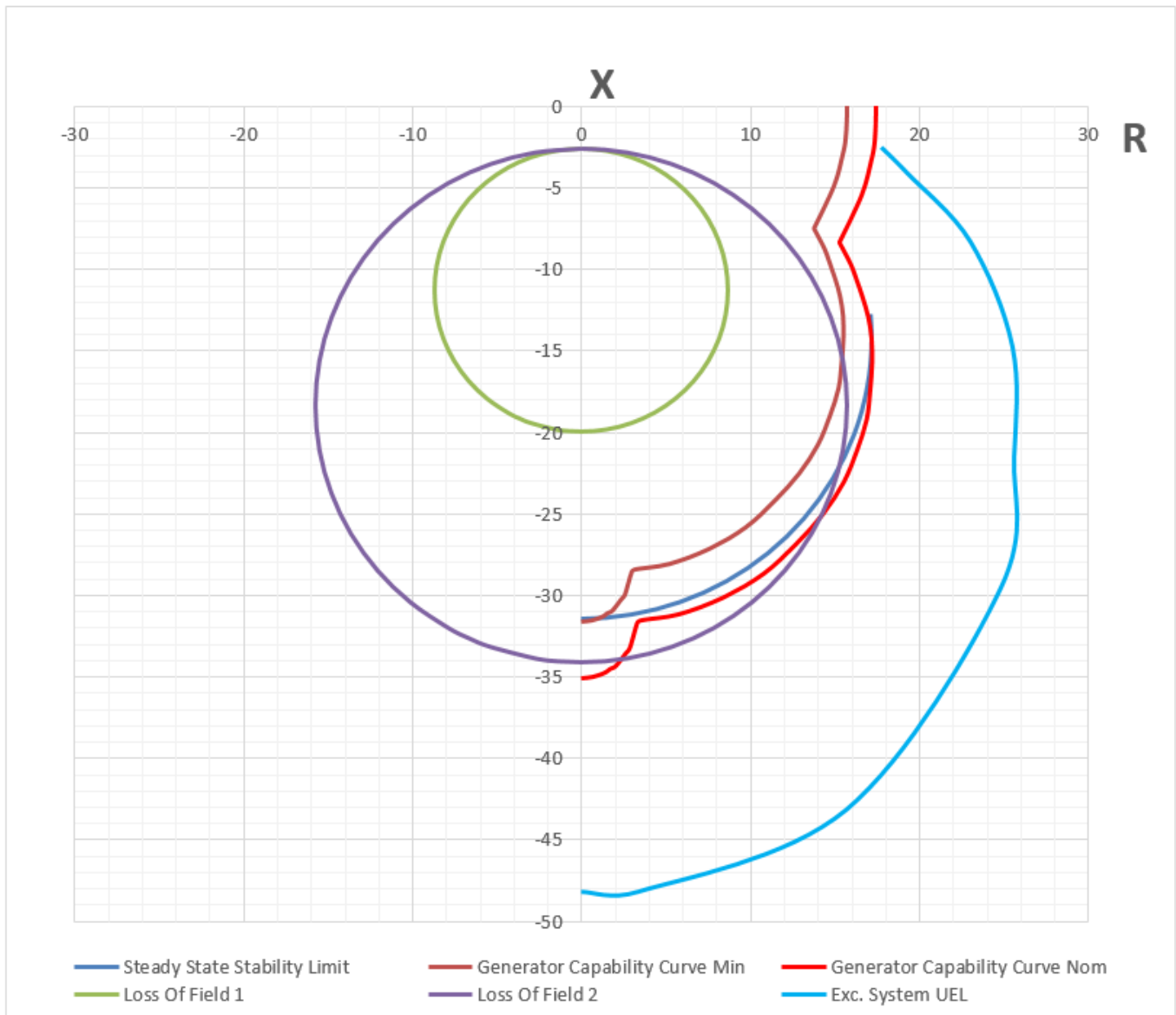

Figure 3.5: Synchronous Generator Underexcitation R-X Coordination

Synchronous Condenser Example

Properly documented, the following calculations may be used to demonstrate compliance for this specific example. Different condenser designs and protection schemes may require modifications to the calculations. An entity should not blindly copy the methodology outlined below; but should have an in-depth understanding of its holistic generation system before making specific coordination decisions. The one-line diagram for the synchronous condenser example calculation is shown in [Figure 3.1](#) and the system parameters are shown below in [Table 3.17](#). This example assumes an entity removed the prime mover of the synchronous generator from [Figure 3.1](#) to convert the machine to a synchronous condenser.

Table 3.17: Synchronous Condenser System Parameters Example Calculations	
Synchronous Condenser Input Descriptions	Input Values
Synchronous Condenser nameplate (MVA @ rated pf):	$MVA_{GEN} = 794 \text{ MVA}$

Table 3.17: Synchronous Condenser System Parameters Example Calculations

Synchronous Condenser Input Descriptions	Input Values
	$PF_{GEN} = 0.90$
Generator rated voltage (Line-to-Line):	$V_{Gen} = 23 \text{ kV}$
Direct Axis Subtransient Reactance, per unit:	$X''_d = 18.4\%$
Direct Axis Transient Reactance, per unit:	$X'_{di} = 30\%$
Direct Axis Synchronous Reactance, per unit:	$X_d = 181\%$
Generator Base Impedance:	$Z_{G_Base} = \frac{V_{gen}^2}{MVA_{GEN}} = 0.666\Omega$
Generator Current transformer (CT) ratio:	$CTR_{Gen} = \frac{25000}{5} = 5000$
Generator Potential transformer (PT) ratio:	$PTR_{Gen} = \frac{13279}{69.28} = 191.67$
Primary to Secondary Impedance Ratio:	$ZTR = \frac{CTR_{Gen}}{PTR_{Gen}} = 28.086$
Nominal relay (secondary) voltage:	$V_{Gen_nom} = \frac{V_{Gen}}{PTR_{Gen}} = 120$
Nominal relay (secondary) current:	$I_{Gen_nom} = \frac{MVA_{GEN}}{(\sqrt{3} \times V_{Gen} \times CTR_{Gen})}$
Generator Step-Up (GSU) Transformer Input Descriptions	Input Values
Generator step-up (GSU) transformer rating:	$MVA_{GSU} = 696 \text{ MVA}$
GSU transformer reactance (696 MVA base):	$X_{GSU_TBASE} = 8.8\%$
GSU transformer MVA base:	$MVA_{GSU_Base} = 696 \text{ MVA}$
GSU Transformer High-side Nameplate Voltage	$V_{GSU_HS} = 230 \text{ kV}$
GSU Transformer Low-side Nameplate Voltage	$V_{GSU_LS} = 22.1 \text{ kV}$
GSU transformer high-side no-load tap Voltage	$V_{GSU_HS_TAP} = 235 \text{ kV}$
GSU transformer turns ratio:	$GSU_{ratio} = \frac{V_{GSU_HS}}{V_{GSU_LS}}$
High-side nominal system voltage (Line-to-Line):	$V_{Sys_nom} = 230 \text{ kV}$
GSU Current transformer (CT) ratio:	$CTR_{GSU} = \frac{3000}{5}$
Unit Auxiliary Transformer (UAT) Input Descriptions	Input Values
UAT nameplate MVA Base:	$MVA_{UAT_Base} = 32 \text{ MVA}$
UAT high-side nameplate voltage:	$V_{UAT_HS} = 21.85 \text{ kV}$
UAT low-side nameplate voltage:	$V_{UAT_LS} = 6.9 \text{ kV}$
Bulk Electric System Descriptions	Input Values

Table 3.17: Synchronous Condenser System Parameters Example Calculations

Synchronous Condenser Input Descriptions	Input Values
System Base MVA:	$MVA_S = 100 \text{ MVA}$
System Base Voltage:	$V_S = 230 \text{ kV}$

Manual Steady State Stability Limit (SSSL):

To calculate the manual SSSL, an entity must determine the system impedance (transfer impedance) from the vantage point of the condenser. In order to identify this impedance, one should identify a configuration that will create a minimum condenser/weak system condition. For this example, we removed the largest transmission line in the switchyard and the largest adjacent generator within the facility. The resultant equivalent impedance will represent a portion of the total system impedance to use in the SSSL calculations.

The SSSL is the same as [Figure 3.1](#) since the system data and generator impedance are identical.

Steady State Stability Limit (SSSL) Characteristic Plot in P-Q Plane:

Using a 0.95 per unit voltage magnitude will define the most limiting SSSL curve for coordination purposes.

The Center Offset in the P-Q plane is:

$$c_{PQ} = 1922.772 \text{ MVAR}$$

The Radius in the P-Q plane is defined by:

$$r_{PQ} = 2318.675 \text{ MVA}$$

Use the following equations to create the characteristic curve of the SSSL in the P-Q plane:

$$P_{SSSL} = r_{PQ} \cos \theta$$

$$Q_{SSSL} = r_{PQ} \sin \theta + c_{PQ}$$

[Table 3.18](#) contains the plot points on the P-Q plane for the manual steady state stability limit.

Table 3.18: Plot Points on the P-Q Plane for the Manual Steady State Stability Limit		
θ	$P_{SSSL_min} \text{ (MW)}$	$Q_{SSSL_min} \text{ (MVAR)}$
-89°	40.47	-395.55
-89.25°	30.35	-395.70
-89.5°	20.23	-395.81
-89.75°	10.12	-395.88
-90°	0	-395.90

Analysis of Condenser Capability

The Generator Capability Curve (GCC) is provided by the manufacturer. The GCC may be represented in either the P-Q plane or the R-X plane or both.

Generator Capability Curve

The Generator Capability Curve may be acquired from the machine OEM. The plot is typically provided on a P-Q axis.

Table 3.19 contains the plot points on the P-Q plane for the generator capability curve.

Table 3.19: Plot Points on the P-Q Plane for the Generator Capability Curve		
pf	P _{Gen} (MW)	Q _{Gen} (MVAR)
0.0	47.64	-436.7
-0.01	7.94	-404.94
-0.05	23.82	-428.76
-0.10	47.64	-436.7

Condenser Over Flux Capability Curve

This curve represents the amount of V/Hz the stator winding can withstand; any level above this curve leaves the condenser susceptible to damage via flux overspill onto non-laminated portions of the stator. The overexcitation capability curve for the condenser may be represented in per-unit quantities from the base voltage at the synchronous condenser terminal. This curve may be acquired from the machine OEM.

Table 3.20 contains the plot points for the synchronous condenser overexcitation capability curve.

Table 3.20: Plot Points for the Synchronous Condenser Overexcitation Capability Curve	
Gen_24 (pu)	Gen_24 _t (sec.)
1.06	10000
1.06	3775
1.07	767
1.08	265
1.09	143
1.10	89
1.12	45
1.14	26
1.16	18.1
1.18	13
1.20	10
1.22	7.94
1.24	6.42
1.26	5.52
1.28	4.75
1.29	4.35
1.30	4.12

Generator Step-Up (GSU) Transformer Over Flux Capability Curve

The overexcitation capability curve for the GSU may be acquired from the transformer OEM or test reports. This curve represents the V/Hz magnitudes the transformer core may be exposed to. If the GSU low-voltage winding has a different base voltage than the condenser terminal, the curve should be converted to the generator base.

$$\text{Eq. (26)} \quad GSU_{24_{Gen_base}} = GSU_{24_{GSU_base}} \times \left(\frac{V_{GSU_LS}}{V_{Gen}} \right)$$

Table 3.21 contains the plot points for the GSU overexcitation capability curve on the generator base.

Table 3.21: Plot Points for the GSU Overexcitation Capability Curve on the Generator Base		
GSU_24 _{GSU_base} (pu)	GSU_24 _{Gen_base} (pu)	GSU_24 _t (sec.)
1.25	1.201	60000
1.27	1.22	6000
1.30	1.249	300
1.32	1.268	60
1.56	1.499	6
1.65	1.585	0.6

Unit Auxiliary Transformer (UAT) Over Flux Capability Curve

The overexcitation capability curve for the UAT may be acquired from the transformer OEM or test reports. This curve represents the V/Hz magnitudes the transformer core may be exposed to. If the UAT high-voltage winding has a different base voltage than the condenser terminal, the curve should be converted to the generator base.

$$\text{Eq. (27)} \quad UAT_{24_{Gen_base}} = UAT_{24_{UAT_base}} \times \left(\frac{V_{UAT_HS}}{V_{Gen}} \right)$$

Table 3.22 contains the plot points for the UAT overexcitation capability curve on the generator base.

Table 3.22: Plot Points for the UAT Overexcitation Capability Curve on the Generator Base		
UAT_24 _{UAT_base} (pu)	UAT_24 _{Gen_base} (pu)	UAT_24 _t (sec.)
1.125	1.069	1500
1.15	1.092	390
1.20	1.14	66
1.25	1.188	27
1.30	1.235	17.40
1.35	1.282	12.60
1.40	1.33	9.6

Condenser Field Winding Overexcitation Capability Curve

The field winding capability represents the thermal overload rating (I^2t) of the field winding. This curve defines the magnitude of current the excitation system may inject into the field winding. Per IEEE C50.13 “Standard for Cylindrical-Rotor Synchronous Generators”, the permissible rotor currents for overexcitation are derived from the following equation:

$$\text{Eq. (28)} \quad T_{Field} = \frac{33.75}{(I_{Field})^2 - 1}$$

Table 3.23 contains the plot points for the field winding thermal capability curve.

Table 3.23: Plot Points for the Field Winding Thermal Capability Curve	
I_{Field} (pu)	T_{Field} (sec)
1.13	121.885
1.25	60
1.46	29.825
2.09	10.02

Analysis of Condenser Voltage Control System

The excitation system limiter and/or trip element set points may be obtained from the excitation system OEM. An entity may request these values in MW/MVAR units and R/X impedance units.

Excitation System Underexcitation Limiter (UEL)

The UEL will prevent the voltage regulator from reducing the internal condenser voltage beyond a level that would exceed the condensers VAR absorption capability and the manual SSSL. The excitation system UEL set points and curve characteristic may be obtained from the excitation system OEM or from field service/test reports. The UEL will coordinate with the protective functions within the excitation system and the Loss of Field relay element. It will also coordinate with the stator core-end capabilities. Therefore, the protection engineer and the excitation system engineer/technician must coordinate their set-points and schemes before the unit can be put in-service and serve grid load. The following example includes both P-Q and R-X values. For a given voltage control system, use the manufacturer provided information (either P-Q, R-X, or both).

Table 3.24 contains the plot points for the excitation system UEL in the P-Q plane.

Table 3.24: Plot Points for the Excitation System UEL in the P-Q Plane	
$P_{\text{AVR UEL}}$ (MW)	$Q_{\text{AVR UEL}}$ (MVAR)
0	-285
20	-285
47	-284

Excitation System Field Winding Overexcitation Limiter (OEL)

The OEL will prevent the excitation system from exceeding field current beyond a magnitude that would exceed the field current thermal capability. The excitation system OEL set points and curve characteristic may be obtained from the excitation system OEM or from field service/test reports. The OEL will coordinate with the protective functions within the excitation system and the relay protection scheme (50, 51, 49, etc.). It will also coordinate with the Condenser Field Winding Capability curve. Therefore, the protection engineer and the excitation system engineer/technician must coordinate their set-points and schemes before the unit can be put in-service and serve grid load.

For this example, an inverse-time OEL was implemented using field current as an operating quantity.

Table 3.25 contains the plot points for the excitation system OEL.

Table 3.25: Plot Points for the Excitation System OEL	
I_{41_OEL} (pu)	$T_{I_{41_OEL}}$ (sec.)
1.0573	633.0
1.0676	315.0
1.0777	208.0
1.0850	140
1.1147	50.0
1.2477	24.0
1.3450	16.0
1.4447	13.0
1.5454	11.0
1.6958	9.0
1.7936	8
1.8941	7.0
1.9899	6.0
200.0	4.0
200.0	0.0

Excitation System Field Winding Overexcitation Protection (OEP)

The purpose of this OEP scheme is to initiate a condenser trip, through the excitation system, for a condition in which the excitation system OEL fails to stop an increase in field current beyond its characteristic curve. The excitation system protection element functions like a relay; therefore, one must treat it as a relay for coordination purposes. The excitation system time overcurrent element will be set to coordinate with the thermal capability curve of the field winding, per IEEE C50.13 or OEM ratings. This scheme should also coordinate with the excitation system OEL by allowing the OEL the opportunity to initiate action first. This thermal limit may be verified with the OEM to ensure an accurate curve is plotted.

This scheme typically uses the nominal field current as an operating quantity. The nominal field current is based on the power potential transformer (PPT) and the load current the excitation system draws. This value may be acquired from the excitation system OEM or field service/test reports.

Nominal field current (I_{41_Nom}):

$$I_{41_Nom} = 0.864$$

Time Overcurrent Pickup:

$$OEP_{P_{pu}} = 1.065$$

Time Overcurrent Time Dial:

$$OEP_{TD} = 2.3$$

Time Overcurrent Curve:

$$OEP_{Curve} = \textit{Moderately Inverse}$$

Table 3.26 contains the plot points for the excitation system OEP.

Table 3.26: Plot Points for the Excitation System OEP	
I_{41_OEP} (pu)	$T_{I_{41_OEP}}$ (sec)
1.109	145.9
1.11	142.7
1.112	136.8
1.123	111.5
1.130	99.9
1.135	93
1.158	70.8
1.216	44.8
1.274	33.2
1.332	26.7
1.39	22.4
1.505	17.3
1.621	14.3
1.737	12.3
1.969	9.8
2.316	7.8
2.895	6.1

Excitation System Stator Volts per Hertz Limiter

The purpose of this limiter is to prevent the excitation system from producing high magnitudes of terminal voltage when the prime mover is not operating at appropriate speeds. The excitation system V/Hz limiter will coordinate with the protective functions within the excitation system and the relay protection scheme (24,59). The limiter will also coordinate with the condenser overexcitation capability curve. The set-point and curve characteristic may be obtained from the excitation system OEM or field service/test reports. This curve is on the generator base voltage since its voltage source comes from PT's at the terminal of the condenser.

For this example, a dual function V/Hz protective function was implemented utilizing a definite-time and inverse time operating characteristic.

Table 3.27 contains the plot points for the excitation system Stator Overexcitation Limiter.

Table 3.27: Plot Points for the Excitation System Stator Overexcitation Limiter	
AVR_{24_Lim} (pu)	$T_{AVR_{24_Lim}}$ (sec.)
1.30	0.70
1.25	1.0
1.20	1.50
1.15	2.20
1.12	3.40
1.10	4.20
1.09	5.20
1.08	7.10
1.07	9.80
1.06	16.90
1.0537	62.0

Analysis of Protection Schemes

Protection functions may be located within a protection system or the condenser control system.

V/Hz Overexcitation Protection Scheme

The condenser V/Hz scheme will initiate a condenser trip for a condition in which the excitation system V/Hz limiter fails to stop an increase in stator voltage, relative to frequency, beyond its characteristic curve. The V/Hz scheme will coordinate with the condenser stator overexcitation capability curve. The scheme will also coordinate with the excitation system V/Hz limiter by allowing the limiter the opportunity to initiate action first. The V/Hz schemes associated with the excitation transformer or the GSU should align with the condenser V/Hz scheme for the design provided in the example.

The Level 1 element will be used as a definite-time element to initiate an alarm and identify an overexcitation condition. This will give the generator operator the opportunity to manually correct the abnormal overexcitation conditions.

Definite-Time Level 1 Element:

$$24D1P = 105 \%$$

$$24D1D = 60 \text{ cycles}$$

The Level 2 element will be used as a definite-time element to initiate a condenser trip during high levels of V/Hz to prevent overexcitation damage. This set-point and time delay will coordinate with the overexcitation capabilities of the condenser to prevent damage. This element will allow enough margin for the excitation control system to correct the abnormal operating conditions before the relay initiates a trip.

Definite-Time Level 2 Element:

$$24D2P2 = 128 \%$$

$$24D2D = 66 \text{ cycles} = 1.10 \text{ sec.}$$

The inverse time element will be used to initiate a condenser trip for low to moderate overexcitation conditions. This curve characteristic will coordinate with the overexcitation capability of the condenser to prevent damage. It will allow enough margin for the excitation control system to correct the abnormal operating condition before the relay initiates a trip.

Inverse Time Pickup:

$$24IP = 106 \%$$

Inverse Time Dial:

$$24ITD = 1.5$$

Inverse Time Curve:

$$24IT_Curve = 1.0$$

Volts/Hz (24) Inverse Time Element Curve Characteristics:

$$\text{Eq. (31)} \quad T_{24_{IT}} = \frac{(0.003 * 24ITD)}{(V_{24_{IT}} - 1)^2} \text{minutes}$$

Table 3.28 contains the calculations of the time delays for the inverse time curve characteristic.

Table 3.28: Calculations of the Time Delays for the Inverse Time Curve Characteristics		
V_{24IT} (pu)	M_{24IT}	T_{24IT} (sec)
1.06	1	75
1.07	1.009	55.1
1.08	1.019	42.2
1.09	1.028	33.3
1.10	1.038	27
1.11	1.047	22.3
1.12	1.057	18.7
1.15	1.085	12
1.18	1.113	8.3
1.20	1.132	6.8
1.25	1.179	4.3
1.28	1.208	3.4

Table 3.29 contains the calculations of the time delays for the definite-time element plot.

Table 3.29: Calculations of the Time Delays for the Definite Time Element Plot	
V_{24DT} (pu)	T_{24IT} (sec)
24D2P2	1.10
24D2P2	3.4

Field Winding Overcurrent (50/51) Overload Protection Scheme

The winding overcurrent scheme will initiate a condenser trip for a condition in which the excitation system OEL fails to stop an increase in field current beyond its characteristic curve. The overcurrent element monitoring the excitation current will coordinate with the thermal capability of the field winding, per IEEE C50.13 or OEM ratings. The scheme will also coordinate with the excitation system OEL by allowing the limiter the opportunity to initiate action first.

Nominal field current (I_{41_Nom}):

$$I_{41_Nom} = 0.864$$

Time Overcurrent Pickup:

$$51P_{pu} = 1.065$$

Time Overcurrent Time Dial:

$$51TD = 12.3$$

Time Overcurrent Curve:

$$51P_{Curve} = U1$$

Time Overcurrent Curve Characteristics:

$$\text{Eq. (33)} \quad T_{51} = 51TD \times \left[0.0226 + \frac{0.0104}{(M_{51}^{0.02} - 1)} \right]$$

Table 3.30 contains the calculations of the curve characteristic for the time overcurrent element.

Table 3.30: Calculations of the Curve Characteristics for the Time Overcurrent Element		
I₅₁ (pu)	M₅₁	T₅₁ (sec)
1.109	1.041	157.5
1.11	1.042	154.1
1.112	1.044	147.7
1.123	1.055	120.4
1.130	1.061	107.9
1.135	1.066	100.4
1.158	1.088	76.5
1.216	1.142	48.4
1.274	1.196	35.9
1.332	1.251	28.8
1.39	1.305	24.2
1.505	1.413	18.7
1.621	1.522	15.4
1.737	1.631	13.3
1.969	1.849	10.6
2.316	2.175	8.4
2.895	2.719	6.6

Condenser Loss of Field (40) Protection Scheme

This example will employ IEEE C37.102 method 1 for the loss of field (LOF) protection scheme. The level 1 element will detect loss of field conditions during heavier load conditions. This element may be plotted in either the P-Q plane or the R-X plane or both. This element does not have to coordinate with the curves identified within PRC-019 because it protects against severe slip frequency (pole slippage), in which the apparent impedance/power swing loci will overshoot the capability curve of the condenser and has a very short time delay. Since the electrical parameters match the synchronous generator in [Figure 3.1](#), this example will use the same loss of field scheme.

Zone 1 Diameter:

$$40Z1P = 17.38 \Omega$$

Zone 1 Offset:

$$40XD1 = -j2.607 \Omega$$

Loss of Field Zone 1 (40) Plot in R-X Plane:

The Zone 1 Mho element center offset is equal to the radius of the element plus the offset of the element from the origin.

Center Offset:

$$c_{40_1_RX} = -11.297 \Omega$$

Center Radius:

$$r_{40_1_RX} = 8.69 \Omega$$

Loss of Field Zone 1 (40) Translation to P-Q Plane:

Zone 1 Offset (primary Ohms):

$$40XD1_{pri} = -j0.1 \Omega$$

Maximum Mho reactance distance from origin:

$$40MAX_{X_sec} = -19.987 \Omega$$

$$40MAX_X = -0.766 \Omega$$

MVA of Offset Setting:

$$MVA_{40XD1} = j5293.333 \text{ MVA}$$

MVA of Maximum Reactance Distance from Origin:

$$MVA_{40Max} = -690.435 \text{ MVA}$$

In the P-Q plane the offset of the Mho circle will be represented by the MVA of the maximum Mho reactance from the origin, since this will produce a small MVA magnitude. The maximum distance of the Mho circle on the reactance axis, from the origin, will be equivalent to the MVA magnitude from the impedance offset setting.

Therefore, the diameter of the Mho Circle in the P-Q plane will equal:

$$40Z1_{PQ} = 4602.899 \text{ MVA}$$

The radius of the Mho Circle in the P-Q plane will equal:

$$r_{40_1_PQ} = 2301.499 \text{ MVA}$$

The center offset of the Mho Circle in the P-Q plane will equal:

$$c_{40_1_PQ} = -2991.884 \text{ MVAR}$$

Table 3.31 contains the plot points on the R-X and P-Q planes for the Loss of Field #1 element.

Table 3.31: Plot Points on the R-X and P-Q Planes for the Loss of Field #1 Element		
θ	P_{40_1} (MW)	Q_{40_1} (MVAR)
90°	0	-690.4
89.75°	10.04	-690.456
89.50°	20.08	-690.522
89.25°	30.12	-690.632

Table 3.31: Plot Points on the R-X and P-Q Planes for the Loss of Field #1 Element

θ	$P_{40 \ 1}$ (MW)	$Q_{40 \ 1}$ (MVAR)
89°	40.16	-690.785

The level 2 element will protect against loss of field during lighter load conditions, where the lower slip frequency will cause higher characteristic impedances and lower asynchronous current magnitudes. This element may be plotted in either the P-Q plane or the R-X plane or both. For this example, this element will coordinate with the varying generator impedance characteristics during a complete loss of field scenario.

Zone 2 Diameter:

$$\begin{aligned} \text{Eq. (53)} \quad 40Z2P &= X_d \times Z_{G_Base} \times ZTR \\ 40Z2P &= j1.81 \times 0.666 \Omega \times 26.086 \\ 40Z2P &= j31.458 \Omega \end{aligned}$$

Zone 2 Offset:

$$\begin{aligned} \text{Eq. (54)} \quad 40XD2 &= 40XD1 \\ 40XD2 &= -j2.607 \Omega \end{aligned}$$

Loss of Field Zone 2 (40) Plot in R-X Plane:

The Zone 2 Mho element center offset is equal to the radius of the element plus the offset of the element from the origin.

Center Offset:

$$c_{40_2_RX} = -18.336 \Omega$$

Center Radius:

$$r_{40_2_RX} = 15.729 \Omega$$

Loss of Field Zone 2 (40) Translation to P-Q Plane:

Zone 2 Offset (primary Ohms):

$$40XD2_{pri} = -j0.1 \Omega$$

Maximum Mho reactance distance from origin:

$$40MAX_{X2_sec} = -34.065 \Omega$$

$$40MAX_{X2} = -1.306 \Omega$$

MVA of Offset Setting:

$$MVA_{40XD2} = j5293.333 \text{ MVA}$$

MVA of Maximum Reactance Distance from Origin:

$$MVA_{40Max_2} = -405.102 \text{ MVA}$$

In the P-Q plane the offset of the Mho circle will be represented by the MVA of the maximum Mho reactance from the origin, since this will produce a small MVA magnitude. The maximum distance of the Mho circle on the reactance axis, from the origin, will be equivalent to the MVA magnitude from the impedance offset setting.

Therefore, the diameter of the Mho Circle in the P-Q plane will equal:

$$40Z_{PQ} = 4888.231 \text{ MVA}$$

The radius of the Mho Circle in the P-Q plane will equal:

$$r_{40_2_PQ} = 2444.116 \text{ MVA}$$

The center offset of the Mho Circle in the P-Q plane will equal:

$$c_{40_2_PQ} = -2849.218 \text{ MVAR}$$

Table 3.32 contains the plot points on P-Q planes for the Loss of Field #2 element.

Table 3.32: Plot Points on the P-Q Planes for the Loss of Field #2 Element		
θ	P_{40_2} (MW)	Q_{40_2} (MVAR)
90°	0	-405.1
89.75°	10.66	-405.02
89.50°	21.32	-405.09
89.25°	31.99	-405.20
89°	42.65	-405.37

Coordination Plots/Diagrams for Compliance Evidence

The following graphs may be used as evidence to demonstrate compliance with the requirements of PRC-019.

The stator overexcitation scheme (**Figure 3.6**) consists of excitation system V/Hz limiter coordination with relay and excitation system V/Hz protection. In addition, the illustration shows the coordination between the relay and excitation system V/Hz protection with the condenser, GSU, and UAT overexcitation capability.

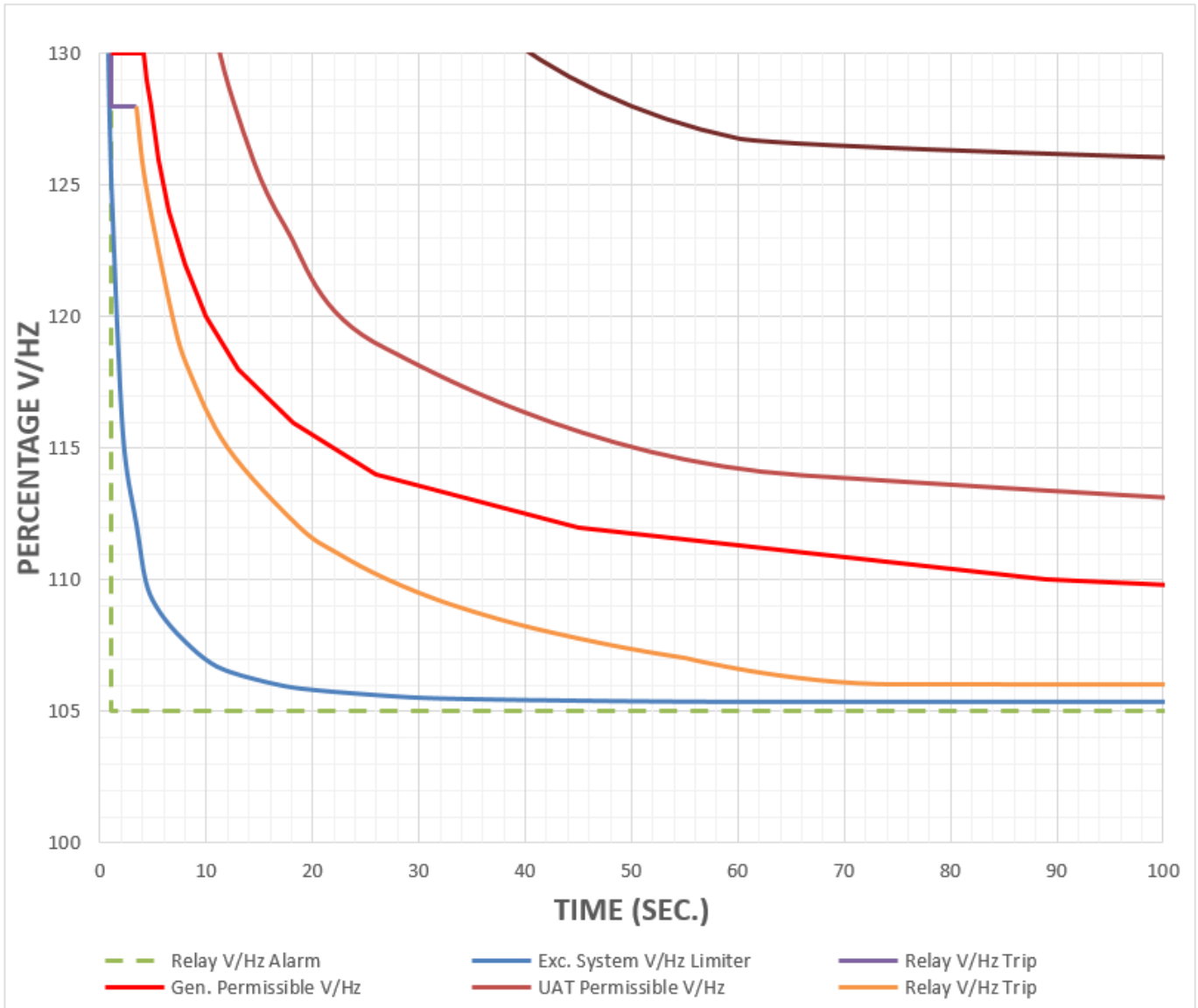

Figure 3.6: Synchronous Condenser Over Flux Coordination

The condenser field winding overexcitation scheme (Figure 3.7) consists of excitation system limiter coordination with relay and excitation system protection. In addition, the illustration shows the coordination between the relay and excitation system V/Hz protection with the field winding thermal capability.

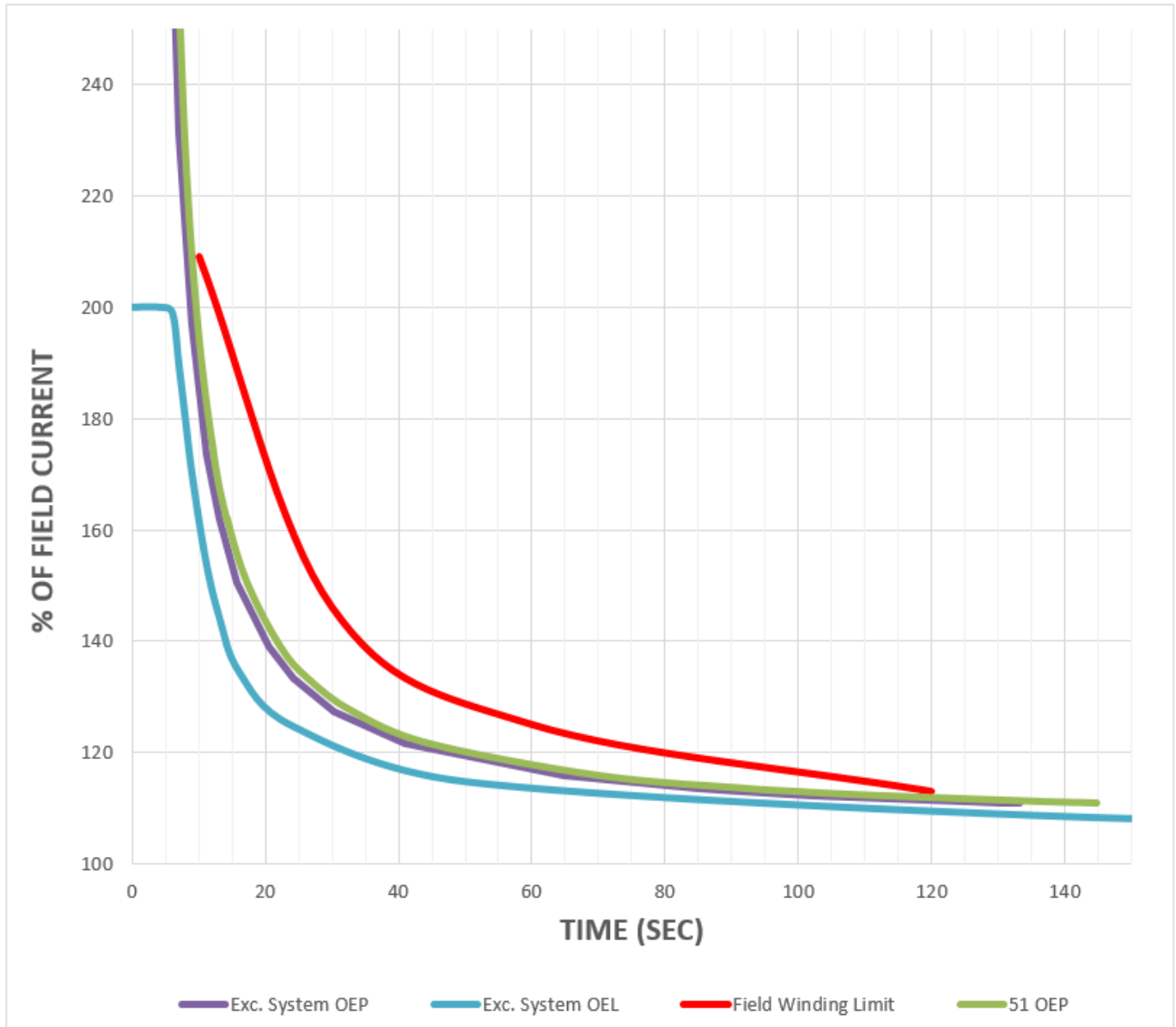

Figure 3.7: Synchronous Condenser Overexcitation Coordination

The condenser underexcitation scheme ([Figure 3.8](#)) consists of excitation system UEL coordination with loss of field protection, with the synchronous condenser absorbing a small amount of real power from the grid to operate. In addition, the illustration shows the coordination between the loss of field protection scheme with the stator end-winding thermal capability.

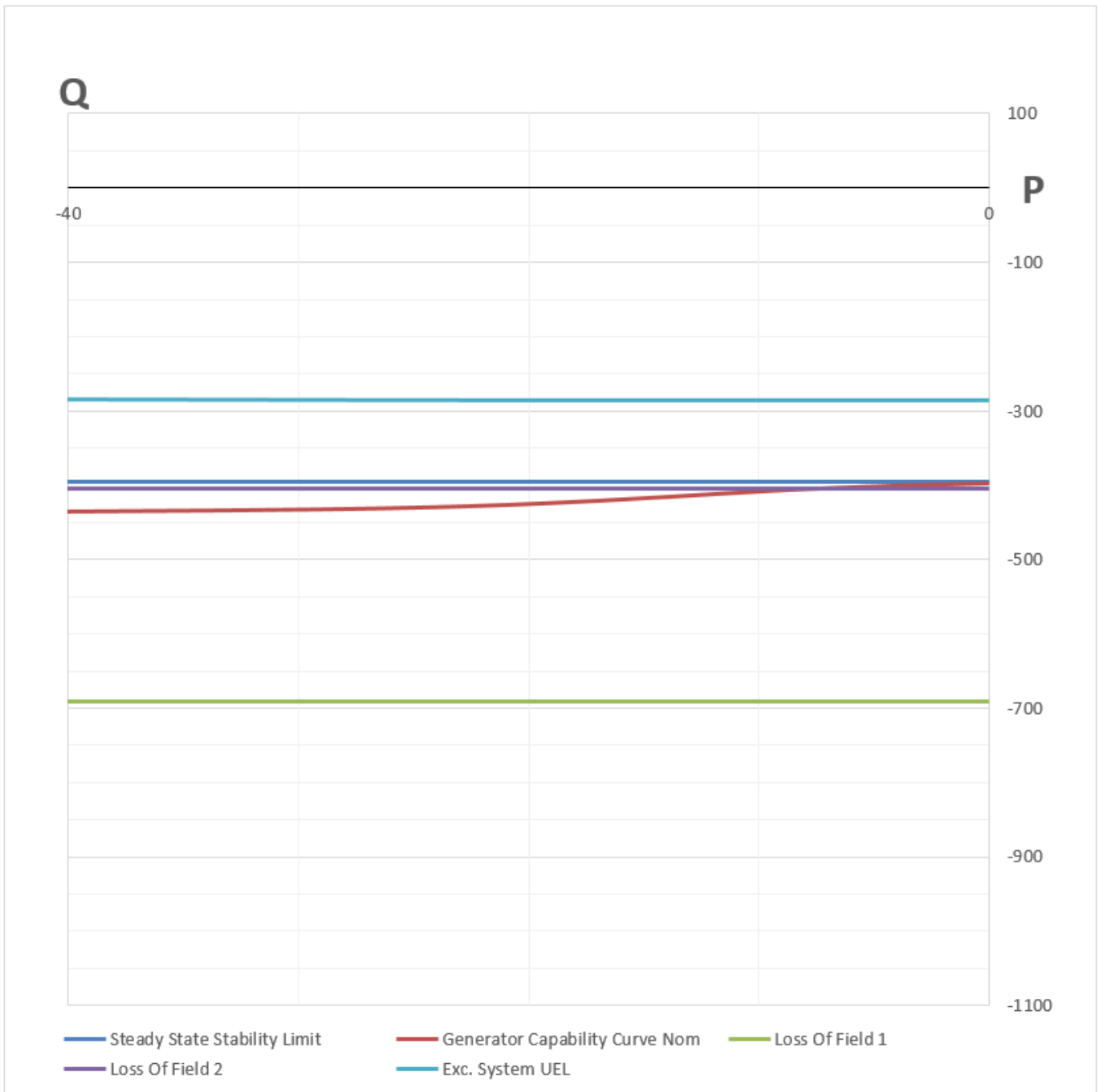

Figure 3.8: Synchronous Condenser Underexcitation Coordination

Figure 3.9 is an illustration of the alternative plot for the condenser underexcitation scheme. This figure consists of excitation system UEL, loss of field protection, and condenser capability coordination over the entire range of the D-curve. The data input for this figure mimics the data points from Figure 3.1. You may refer to the data tables in Table 3.1 for a detailed breakdown of this figure. Even though this is not an accurate representation of the real power out of the machine, this depiction is suitable for proving PRC-019 coordination.

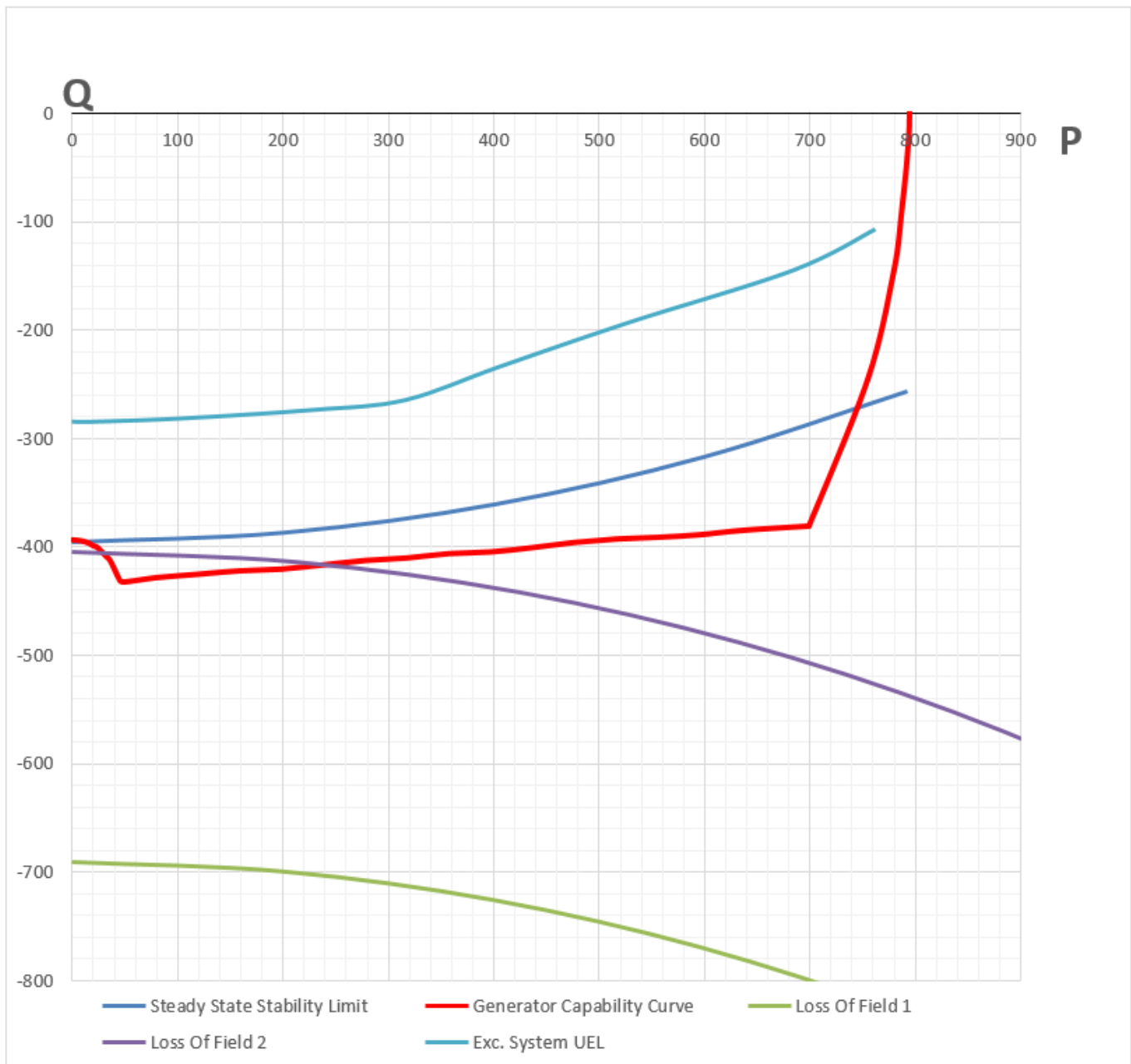

Figure 3.9: Synchronous Condenser Alternate Underexcitation Coordination

Dispersed Power Producing Resources Example

Properly documented, the following calculations may be used to demonstrate compliance for this specific example. It is an entity's responsibility to determine the design and configuration of their control and protection schemes. Different generator designs and protection schemes may require modifications to the calculations. An entity should not blindly copy the methodology outlined below; but should have an in-depth understanding of its holistic generation system before making specific coordination decisions.

The one-line diagram for example calculations is shown in [Figure 3.10](#) and the system parameters are shown below in [Table 3.33](#). Connections for external relays are identified throughout the IBR generating facility. These protection systems are multi-function microprocessor relays that are capable of implementing the protective function identified in this section.

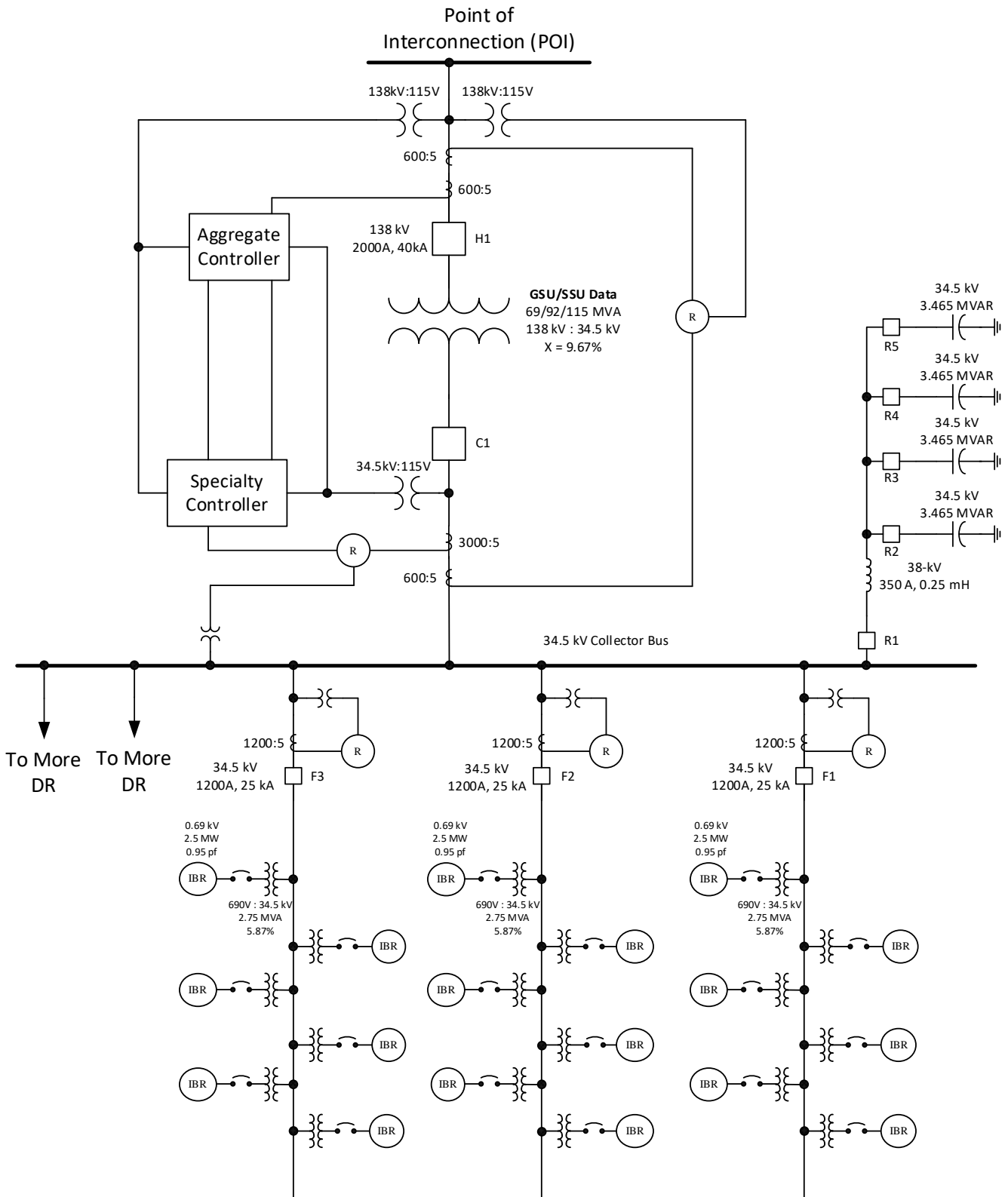

Figure 3.10: Dispersed Power Producing Resource Sample System

Table 3.33: Dispersed Power Producing Resource System Parameters Example Calculations

Inverter Based Resource Input Descriptions	Input Values
IBR Generator nameplate (MW @ rated pf and voltage):	$MW_{A_GEN} = 2.5 \text{ MW}$
	$PF_{A_GEN} = 0.95$
IBR Generator rated voltage (Line-to-Line):	$V_{A_Gen} = 0.69 \text{ kV}$
Total Number of Inverters	$Gen_{Total} = 40$
Pad-mount Transformer Input Descriptions	Input Values
Pad-mount transformer rating:	$MVA_{Pad} = 2.75 \text{ MVA}$
Pad-mount transformer reactance:	$X_{Pad} = 5.87\%$
Pad-mount Transformer Nameplate High-side Voltage	$V_{Pad_HS} = 34.5 \text{ kV}$
Pad-mount Transformer Nameplate Low-side Voltage	$V_{Pad_LS} = 0.69 \text{ kV}$
Generator Step-Up (GSU) Transformer Input Descriptions	Input Values
Generator step-up (GSU) transformer rating:	$MVA_{GSU} = 115 \text{ MVA}$
GSU transformer reactance (69 MVA base):	$X_{GSU_TBASE} = 9.67\%$
GSU transformer MVA base:	$MVA_{GSU_Base} = 69 \text{ MVA}$
GSU Transformer Nameplate High-side Voltage	$V_{GSU_HS} = 138 \text{ kV}$
GSU Transformer Nameplate High-side Tap Voltage	$V_{GSU_HS_Tap} = 138 \text{ kV}$
GSU Transformer Nameplate Low-side Voltage	$V_{GSU_LS} = 34.5 \text{ kV}$
GSU Low-Side Current Transformer (CT) ratio:	$CTR_{GSU_LS} = \frac{3000}{5}$
GSU Low-Side Potential Transformer (PT) ratio:	$PTR_{GSU_LS} = \frac{34500}{115}$
GSU High-Side Current Transformer (CT) ratio:	$CTR_{GSU_HS} = \frac{600}{5}$
GSU High-Side Potential Transformer (PT) ratio:	$PTR_{GSU_HS} = \frac{138000}{115}$
High-side nominal GSU voltage (Line-to-Ground):	$V_{GSU_HS_nom} = \frac{V_{GSU_HS}}{PTR_{GSU_HS} \times \sqrt{3}} = 66.4$
Low-side nominal GSU voltage (Line-to-Ground):	$V_{GSU_LS_nom} = \frac{V_{GSU_LS}}{PTR_{GSU_LS} \times \sqrt{3}} = 66.4$
Collector Bus Input Descriptions	Input Values
Collector Bus Base Voltage:	$V_{Collector} = 34.5 \text{ kV}$

Table 3.33: Dispersed Power Producing Resource System Parameters Example Calculations

Capacitor Bank Input Descriptions	Input Values
Cap Bank MVAR:	$MVAR_{Cap} = 4 \times 3.465 \text{ MVAR} = 13.86 \text{ MVAR}$
Cap Bank Base Voltage:	$V_{Cap} = 34.5 \text{ kV}$
Cap Bank Current Transformer (CT) ratio:	$CTR_{CAP} = \frac{1200}{5}$
Cap Bank Potential Transformer (PT) ratio:	$PTR_{CAP} = \frac{34500}{115}$
Point of Interconnection Descriptions	Input Values
Line Current Transformer (CT) ratio:	$CTR_{Line} = \frac{1200}{5}$
Line Voltage Transformer (VT) ratio:	$VTR_{Line} = \frac{138000}{115}$
System Base MVA:	$MVA_S = 100 \text{ MVA}$
System Base Voltage:	$V_S = 138 \text{ kV}$

For this example, voltage control occurs at the Point of Interconnection (POI) via the plant controller (aggregate controller). The plant controller will operate in Voltage Control Mode, monitoring the grid level voltage magnitude and phase angle. It will use these measurements as a reference to send signals to the individual inverters within the IBR generating facility. This will allow the inverters to track the grid voltage and operate in a “grid following” manner.

Analysis of Dispersed Power Producing Resource Capability

The inverter capability is typically provided by the inverter OEM. These capabilities may vary widely since there are different types of inverters and various manufacturers. Therefore, an entity must obtain accurate data from the OEM.

Dispersed Power Producing Resource Data

Each inverter within the IBR generating facility has the same nameplate ratings. The MVA rating will provide the maximum amount of power the inverter can output.

IBR Generator rated MVA:

$$\begin{aligned} \text{Eq. (69)} \quad MVA_{A_GEN} &= \frac{MW_{A_GEN}}{PF_{A_GEN}} \\ MVA_{A_GEN} &= \frac{2.5 \text{ MW}}{0.95} \\ MVA_{A_GEN} &= 2.632 \text{ MVA} \end{aligned}$$

IBR Generator rated MVAR:

$$\begin{aligned} \text{Eq. (70)} \quad MVAR_{A_GEN} &= MVA_{A_GEN} \times \sin(\cos^{-1} PF_{A_GEN}) \\ MVAR_{A_GEN} &= 2.632 \text{ MVA} \times \sin(\cos^{-1} 0.95) \\ MVAR_{A_GEN} &= 0.822 \text{ MVAR} \end{aligned}$$

Total IBR generating facility Generator MW:

$$\text{Eq. (71)} \quad MW_{A_GEN_T} = MW_{A_GEN} \times Gen_{Total}$$

$$MW_{A_GEN_T} = 2.5 \text{ MW} \times 40$$

$$MW_{A_GEN_T} = 100 \text{ MW}$$

Total IBR generating facility Generator MVA:

$$\text{Eq. (72)} \quad MVA_{A_GEN_T} = MVA_{A_GEN} \times Gen_{Total}$$

$$MVA_{A_GEN} = 2.632 \text{ MVA} \times 40$$

$$MVA_{A_GEN} = 105.28 \text{ MVA}$$

Total IBR Generating Facility Generator MVAR:

$$\text{Eq. (73)} \quad MVAR_{A_GEN_T} = MVAR_{A_GEN} \times Gen_{Total}$$

$$MVAR_{A_GEN_T} = 0.822 \text{ MVAR} \times 40$$

$$MVAR_{A_GEN_T} = 32.88 \text{ MVAR}$$

IBR Voltage Analysis

The inverters are capable of riding-through voltage excursions at their respective AC terminals. The inverter low-voltage ride-through (LVRT) and high-voltage ride-through (HVRT) curves define the unit's capability to withstand voltage deviations. These curves also define the voltage protection set points and curve characteristic within the inverter control system. If an inverter experiences a voltage excursion beyond this characteristic, then the inverter control system will initiate a trip. Since voltage is being regulated at the POI, any transformer no-load tap changer (NLTC) settings between the IBR unit terminal and the POI should be taken into consideration. The inverter HVRT and LVRT capability/protection curves may be acquired from the inverter OEM.

Table 3.34 contains the plot points for the inverter voltage ride-through capabilities (steady state capabilities).

Table 3.34: Plot Points for the Inverter Voltage Ride-through Capabilities (Steady State Capabilities)			
$V_{\text{Inverter_HVRT}} \text{ (pu)}$	$T_{\text{HVRT}} \text{ (sec)}$	$V_{\text{Inverter_LVRT}} \text{ (pu)}$	$T_{\text{LVRT}} \text{ (sec)}$
1.10	5	0.90	5
1.20	5	0.10	5
1.20	0.5	0	5
1.30	0.5		
1.30	0.0016		

Analysis of Collector System

An entity may evaluate capabilities/limitations associated with the collector bus of the IBR generating facility.

Bus Continuous Voltage Capability

For this example, the engineering of the collector system used ANSI C84.1 as one of the design criteria for voltage capability. Per ANSI C84.1, the maximum continuous operating voltage for a 34.5 kV system is 1.05 per unit of nominal voltage. For this example, the continuous voltage capability of the 34.5 kV collector bus was designed to be within +/- 5% of nominal voltage.

Collector Bus Continuous Upper Voltage Limit:

$$V_{Collector_max_pu} = 105\%$$

$$V_{Collector_max} = 105\% \times V_{Collector}$$

$$V_{Collector_max} = 36.2 \text{ kV}$$

Collector Bus Continuous Lower Voltage Limit:

$$V_{Collector_min_pu} = 95\%$$

$$V_{Collector_min} = 95\% \times V_{Collector}$$

$$V_{Collector_min} = 32.8 \text{ kV}$$

Analysis of Collector Bus VAR Support (Cap Bank, Synchronous Condenser, etc.)

An entity may consider reactive compensating devices into the total power output capability of their plant. If the IBR generating facility has these devices, then this output capability should be used as a reference point for protection coordination purposes.

Short Time Overvoltage Capability

Per IEEE C37.99, the maximum continuous overvoltage capability of a capacitor unit is 110% of the rated voltage. IEEE 1036 defines the characteristic curve for prohibited operation above 100% of rated voltage. This curve was used as a basis for the capacitor bank equipment capability.

Table 3.35 contains the plot points for the Cap Bank overexcitation capability curve on the collector bus base voltage.

Table 3.35: Plot Points for the Cap Bank Overexcitation Capability Curve on the Collector Bus Base Voltage	
V_{Cap Lim} (pu)	T_{Cap} (sec)
2.20	0.1
2.0	0.25
1.70	1
1.40	15
1.30	60

Analysis of Point of Interconnection (POI)

The POI for a dispersed power resource is typically the high-voltage side of the GSU transformer or Station Step-up Transformer (SSU) transformer.

POI Voltage Limits

The voltage capabilities at the terminal of the inverters will coordinate with the voltage limitations of the collector system and the interconnecting transmission system (POI). The interconnecting transmission system voltage limitations are typically outside of the inverter steady state voltage limitations. An inverter typically has a steady state voltage range of +/- 10% AC terminal voltage before they go into FRT mode. The voltage limit for this example interconnecting transmission system is defined as +14/-16 kV from a 138-kV reference point. In this example, the limit was defined by the Transmission Owner engineering design.

POI Upper Voltage Limit:

$$V_{POI_max_pu} = \frac{(138kV + 14kV)}{V_S}$$

$$V_{POI_max_pu} = \frac{(138kV + 14kV)}{138kV}$$

$$V_{POI_max_pu} = 1.10$$

POI Lower Voltage Limit:

$$V_{POI_min_pu} = \frac{(138kV - 16kV)}{V_S}$$

$$V_{POI_min_pu} = \frac{(138kV - 16kV)}{138kV}$$

$$V_{POI_min_pu} = 0.884$$

Analysis of Protection Schemes

Protection schemes may be located within protection systems or control systems throughout the IBR generating facility. See [Figure 3.10](#).

Feeder Undervoltage (27) Protection Settings

Each feeder has a designated relay to provide protection for the feeder circuit. Each relay has undervoltage settings that are programmed to trip the feeder off-line.

Level 1 Definite-Time Phase Undervoltage Element:

$$27P1P_{Fdr_sec} = 10 V_{sec}$$

$$27P1P_{Fdr_pu} = \frac{27P1P_{Fdr_sec}}{V_{GSU_LS_nom}}$$

$$27P1P_{Fdr_pu} = \frac{10 V_{sec}}{66.4 V_{sec}}$$

$$27P1P_{Fdr_pu} = 0.151$$

$$T_{27P1P_Fdr} = 330 \text{ cycles} = 5.5 \text{ sec}$$

Collector Bus Overvoltage (59) Protection Settings

This voltage scheme will coordinate with the collector bus and associated equipment voltage limitations.

Level 1 Definite-Time Phase Overvoltage Element:

$$59P1P_{CollectorBus_pu} = 1.10$$

$$59P1P_{CollectorBus_sec} = 59P1P_{LS_pu} \times V_{GSU_LS_nom}$$

$$59P1P_{CollectorBus_sec} = 1.10 \times 66.4 V_{sec}$$

$$59P1P_{CollectorBus_sec} = 73.04 V_{sec}$$

$$T_{59P1P_CollectorBus} = 1800 \text{ cycles} = 30 \text{ sec}$$

Level 2 Definite-Time Phase Overvoltage Element:

$$\begin{aligned}
 59P2P_{CollectorBus_pu} &= 1.30 \\
 59P2P_{CollectorBus_sec} &= 59P2P_{LS_pu} \times V_{GSU_LS_nom} \\
 59P2P_{CollectorBus_sec} &= 1.30 \times 66.4 \\
 59P2P_{CollectorBus_sec} &= 86.32 V_{sec}
 \end{aligned}$$

$$T_{59P2P_CollectorBus} = 15 \text{ cycles} = 0.25 \text{ sec}$$

POI Undervoltage (27) Protection Settings

The voltage protection scheme will coordinate with the voltage limitations of the interconnecting system

Level 1 Definite-Time Phase Undervoltage Element:

$$\begin{aligned}
 27P1P_{POI_sec} &= 39.84 V_{sec} \\
 27P1P_{POI_pu} &= \frac{27P1P_{HS_sec}}{V_{GSU_LS_nom}} \\
 &= \frac{39.84 V_{sec}}{66.4 V_{sec}} \\
 27P1P_{POI_pu} &= 0.6
 \end{aligned}$$

$$T_{27P1P_POI} = 420 \text{ cycles} = 7.0 \text{ sec}$$

Level 2 Definite-Time Phase Undervoltage Element:

$$\begin{aligned}
 27P2P_{POI_sec} &= 57.77 V_{sec} \\
 27P2P_{POI_pu} &= \frac{27P2P_{HS_sec}}{V_{GSU_LS_nom}} \\
 &= \frac{57.77 V_{sec}}{66.4 V_{sec}} \\
 27P2P_{POI_pu} &= 0.87
 \end{aligned}$$

$$T_{27P2P_POI} = 600 \text{ cycles} = 10 \text{ sec}$$

POI Overvoltage (59) Protection Settings

The voltage protection scheme will coordinate with the voltage limitations of the interconnecting system.

Level 1 Definite-Time Phase Overvoltage Element:

$$\begin{aligned}
 59P1P_{POI_sec} &= 73.79 V_{sec} \\
 59P1P_{POI_pu} &= \frac{59P1P_{HS_sec}}{V_{GSU_HS_nom}} \\
 &= \frac{73.79 V_{sec}}{66.4 V_{sec}} \\
 59P1P_{POI_pu} &= 1.11
 \end{aligned}$$

$$T_{59P1P_POI} = 300 \text{ cycles} = 5 \text{ sec}$$

The level 2 element will provide faster tripping for more severe levels of overvoltage. This element will also provide coordination with the capacitor bank voltage limitations.

Level 2 Definite-Time Phase Overvoltage Element:

$$59P2P_{POI_sec} = 78.82 V_{sec}$$

$$59P2P_{POI_pu} = \frac{59P2P_{HS_sec}}{\frac{V_{GSU_HS_nom}}{78.82 V_{sec}}}$$

$$59P2P_{POI_pu} = \frac{66.4 V_{sec}}{78.82 V_{sec}}$$

$$59P2P_{POI_pu} = 1.19$$

$$T_{59P2P_POI} = 12 \text{ cycles} = 0.2 \text{ sec}$$

Coordination Plots/Diagrams for Compliance Evidence

The following graphs may be used as evidence to demonstrate compliance with the requirements of PRC-019.

The inverter voltage ride through scheme ([Figure 3.11](#)) consists of inverter LVRT and HVRT coordination with feeder protection.

Inverter Coordination

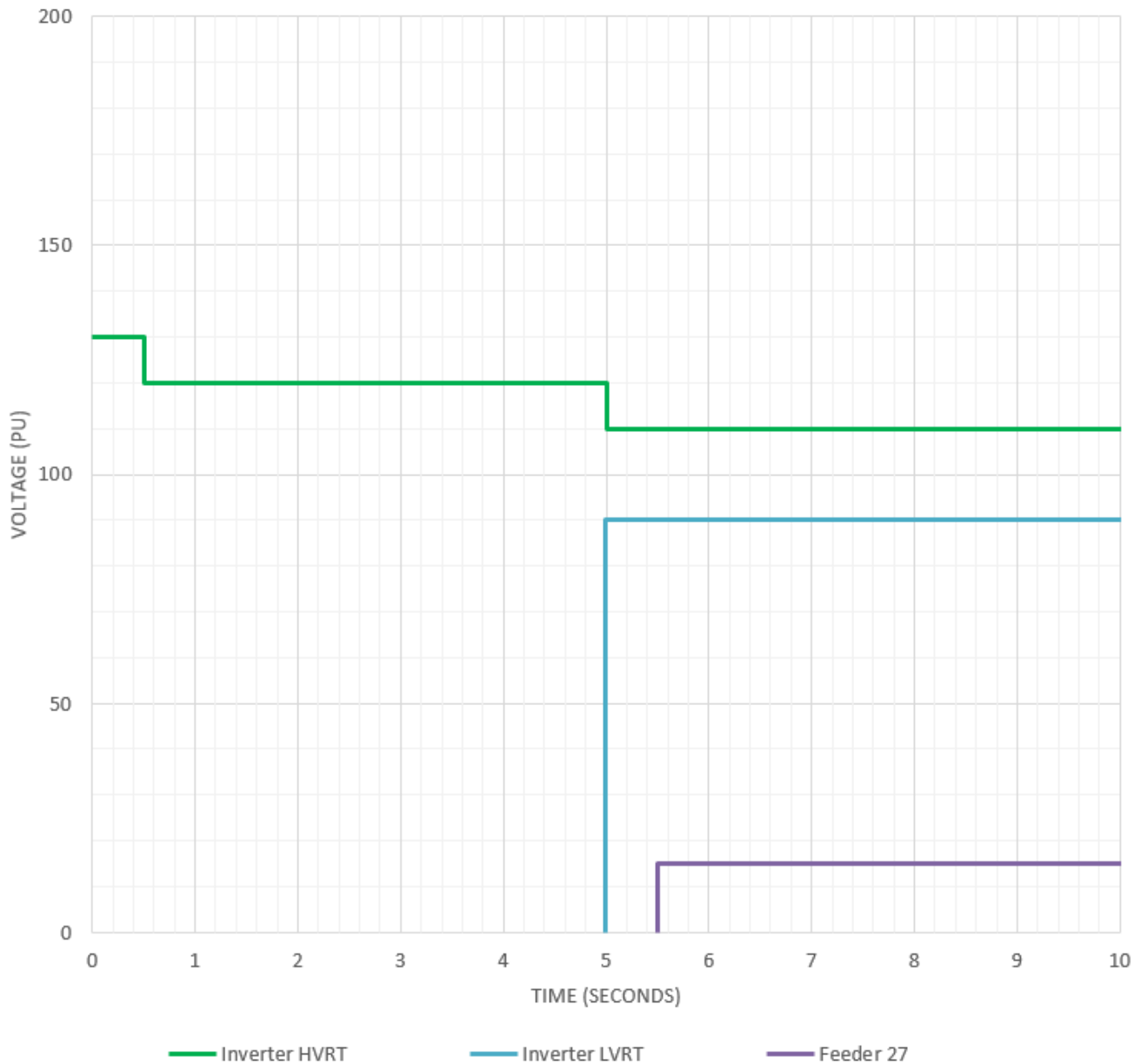

Figure 3.11: Inverter Voltage Coordination

The collector bus scheme ([Figure 3.12](#)) consists of voltage protection, associated with the collection bus, coordination with capacitor bank.



Figure 3.12: Collector Bus Voltage Coordination

The point-of-interconnection scheme ([Figure 3.13](#)) consists of voltage protection, associated with the high-side of the main power transformer, coordination with the interconnecting system capabilities.

POI Coordination

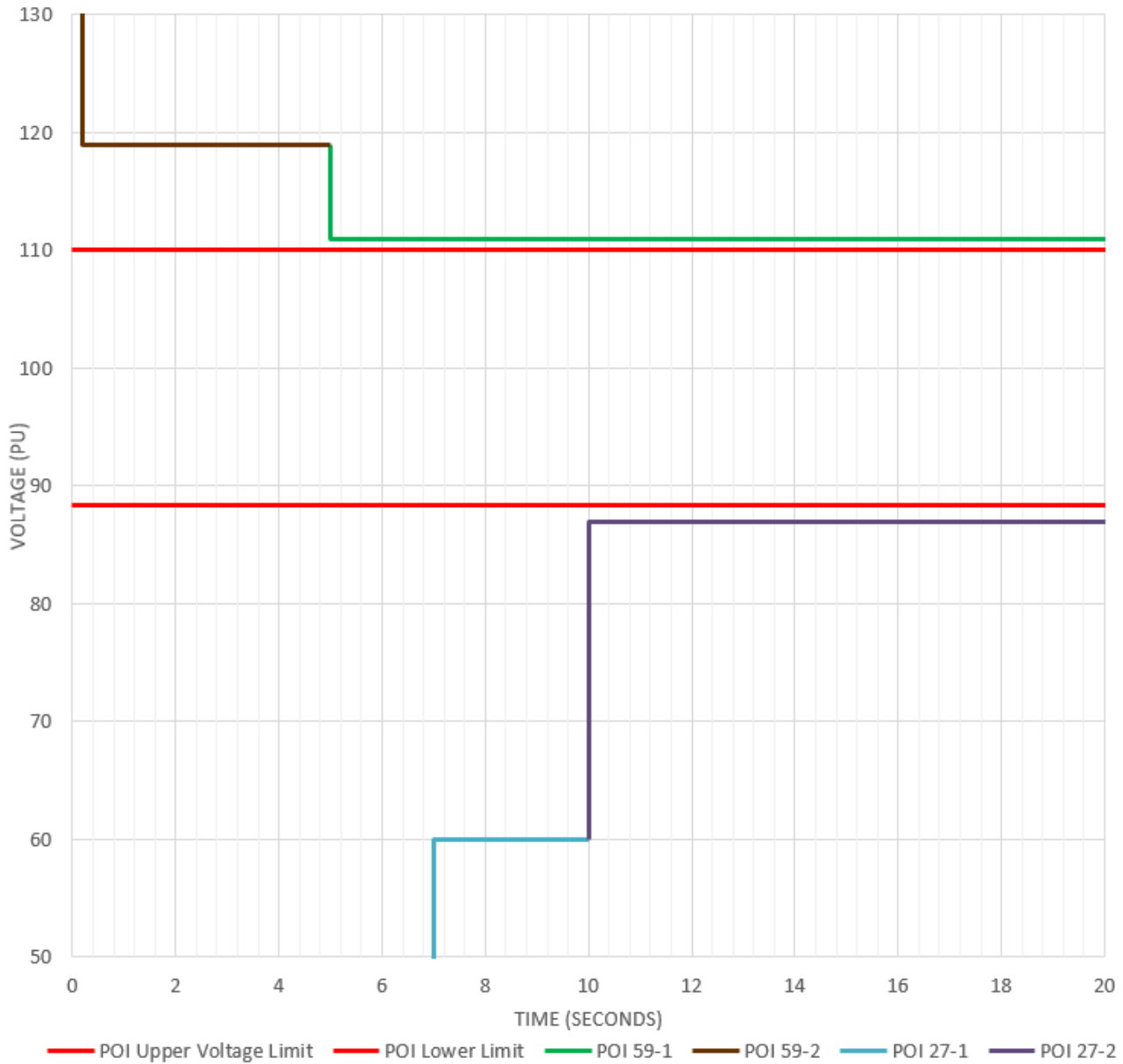

Figure 3.13: Dispersed Power Producing Resource POI Voltage Coordination

Chapter 4: References

- “Protective Relaying for Power Generation Systems”, Boca Raton, FL, Taylor & Francis, 2006, Reimert, Donald
- “IEEE C37.102, IEEE Guide for AC Generator Protection”
- “IEEE C50.13, IEEE Standard for Cylindrical-Rotor 50 Hz and 60 Hz Synchronous Generators Rated 10 MVA and Above”
- “IEEE C37.106, IEEE Guide for Abnormal Frequency Protection for Power Generating Plants”
- “ANSI C84.1, American National Standard for Electric Power Systems and Equipment -Voltage Ratings (60 Hz)”
- “IEEE Std C37.99, IEEE Guide for the Protection of Shunt Capacitor Banks”
- “IEEE Std 1036, IEEE Guide for the Application of Shunt Power Capacitors”
- “NERCBPS-Connected Inverter-Based Resource Performance Guideline”
- “IEEE Std 421.5, IEEE Recommended Practice for Excitation System Models for Power System Stability Studies”
- “Power System Stability and Control”, McGraw-Hill 1994, Prahba Kundur
- Alla, M.,Guzman, A., Finney, D., Fischer, N., “Capability Curve-Based Generator Protection Minimizes Generator Stress and Maintains Power System Stability” in 45th Annual Western Protective Relay Conference, October 2018.

Appendix A: Contributors

This document was developed with the coordination of the NERC System Protection and Control Working Group. We would like to thank the following for their contributions:

Task Force Members
Rich Bauer
Aristides Martinez
Michael Thompson
Matt Manley
Venkat Reddy
Jeff Roesch
Gary Custer
Christopher Milan
Rajat Majumder
Siddharth Pant
Matthew Richwine
Jason Buneo
Greg Kern
Leonardo Lima
Jack Norris
Andrew Sloan
Jason Eruneo

Other Contributors
Lynn Schroeder
Terry Volkman
Mark Gutzmann
Maysam Radvar